

Operating, Maintenance & Parts Manual

EC Series



1/4 Ton
EC0516
EC0532
EC0564

1/2 Ton
EC1009
EC1016
EC1032

1 Ton
EC2004
EC2008
EC2012
EC2016

2 Ton
EC4006
EC4008
3 Ton
EC6005

Follow all instructions and warnings for inspecting, maintaining and operating this hoist.

The use of any hoist presents some risk of personal injury or property damage. That risk is greatly increased if proper instructions and warnings are not followed. Before using this hoist, each operator should become thoroughly familiar with all warnings, instructions, and recommendations in this manual. Retain this manual for future reference and use.

Forward this manual to the hoist operator. Failure to operate the equipment as directed in the manual may cause injury.

Should you have any questions regarding this product, please call Coffing Hoists at (800) 477-5003.

Before using the hoist, fill in the information below:

Model No. _____

Serial No. _____

Purchase Date _____

COFFING®
HOISTS

TABLE OF CONTENTS

SECTION I	INTRODUCTION	
1-1	General Information	3
1-2	Safety Standards	3
1-3	Hoist Construction and Features	3
1-4	Basic Hoist Data.....	3
1-5	Application Information	3
1-6	Warranty	3
SECTION II	INSTALLATION	
2-1	Safety Notes	4
2-2	Hanging the Hoist.....	4
2-3	Power Supply Connection	4
2-4	Vent Plug	4
2-5	Chain Lubrication	4
2-6	Testing.....	4
2-7	Trolley Installation	4-5
2-8	Chain Container Installation.....	6
SECTION III	OPERATION	
3-1	General	5
3-2	Safety Notes	5
3-3	Handling the Load	5-6
3-4	Overload Limiting Protection.....	6
SECTION IV	INSPECTION	
4-1	General	6
4-2	Frequent Inspection	6
4-3	Periodic Inspection	6
4-4	Load Brake Function Check.....	8
4-5	Chain Inspection	8-9
4-6	Hook Throat Opening.....	9
SECTION V	MAINTENANCE AND REPAIR	
5-1	General	9
5-2	Limit Switch Adjustment.....	9-10
5-3	Motor Brake Adjustment.....	10
5-4	Top Suspension Removal and Replacement.....	10
5-5	Chain Replacement.....	10-11
5-6	Lubrication	11-12
SECTION VI	TROUBLESHOOTING	
6-1	General	13-14
SECTION VII	WIRING	
7-1	Voltage Conversion.....	15
7-2	Wiring Diagrams	15-17
SECTION VIII	ILLUSTRATED PARTS LISTS	
8-1	General.....	18
8-2	How to Use the Parts List.....	18
8-3	How to Order Replacement Parts	18
FIGURE 8-1	Suspension Assembly Kits.....	19
FIGURE 8-2	Basic Hoist	20
FIGURE 8-3A	Motor Parts (One Speed).....	22
FIGURE 8-3B	Motor Parts (Two Speed).....	23
FIGURE 8-4A	Controller Area (Single Phase).....	24
FIGURE 8-4B	Controller Area (Three Phase).....	25
FIGURE 8-5	Transmission	26
FIGURE 8-6	Chaining Parts	28
FIGURE 8-7A	Pushbutton (Single Speed Hoist)	30
FIGURE 8-7B	Pushbutton (Two Speed Hoist).....	31
FIGURE 8-8A	Standard Limit Switch Parts.....	32
FIGURE 8-8B	Long Lift Limit Switch Parts	33
FIGURE 8-9	Motor Brake Parts.....	34
FIGURE 8-10A	Bottom Block (¼ Ton & ½ Ton).....	35
FIGURE 8-10B	Bottom Block (1 Ton).....	36
FIGURE 8-10C	Bottom Block (Double Chain).....	36
FIGURE 8-10D	Bottom Block (Triple Chain).....	36
FIGURE 8-11	Chain Container Parts.....	37
SECTION IX	DO'S AND DO NOT'S	38

SECTION I INTRODUCTION

1-1. General Information

This manual provides information for the safe operation and maintenance of Coffing® EC-1 Series Hoists. All persons operating or maintaining these hoists should be familiar with the information contained herein. Adherence to the precautions, procedures, and maintenance practices described should ensure long reliable operation. Suggestions for improvements to this manual are solicited.

1-2. Safety Standards

All persons concerned with the installation, operation, inspection and maintenance of these hoists are urged to read American National Standard (ANSI) B30.16. That Standard contains valuable guidelines concerning practices designed to minimize hazards associated with the use of overhead hoisting equipment. ANSI B30.16 also contains detailed procedures for establishing hoist inspection and maintenance programs and can be of significant assistance in maintaining compliance with OSHA regulations.

1-3. Hoist Construction and Features

Strong, lightweight aluminum alloy die castings provide a compact, protective enclosure for the mechanical and electrical components of Coffing EC-1 Series Hoists. Heat treated alloy steel gearing operates in an oil bath to provide the most reliable lubrication and effective heat dissipation.

EC-1 Series Hoists incorporate the following features:

- a. Overload limiting clutch.
- b. Completely independent mechanical and electrical brakes.
- c. Adjustable limit switches.
- d. Tough, nylon weatherproof pushbutton stations.
- e. Steel strain cable inside pushbutton cord.
- f. Transformer isolated, low-voltage pushbutton controls.
- g. Quick voltage conversion on dual-voltage units.

TABLE 1-1. BASIC HOIST DATA

Model No.	Rated Load (lb.)	Lift Speed at Rated Load (ft. per min.)	Motor HP
EC-0516	500	16	1/4
EC-0532	500	32	1/2
EC-0564	500	64	1
EC-1009	1000	9	1/4
EC-1016	1000	16	1/2
EC-1032	1000	32	1
EC-2004	2000	4	1/4
EC-2008	2000	8	1/2
EC-2012	2000	12	1
EC-2016	2000	16	1
EC-4006	4000	6	1
EC-4008	4000	8	1
EC-6005	6000	5	1

1-4. Basic Hoist Data

The basic hoist models covered by this manual are listed in Table 1-1.

1-5. Application Information

This hoist is intended for general industrial use in the lifting and transporting of freely suspended material loads within its rated load. Prior to installation and operation, the user should review his application for abnormal environmental or handling conditions and to observe the applicable recommendations as follows:

- a. **Adverse Environmental Conditions.** Do not use the hoist in areas containing flammable vapors, liquids, gases or any combustible dusts or fibers. Refer to Article 500 of *The National Electric Code*. Do not use this hoist in highly corrosive, abrasive or wet environments. Do not use this hoist in applications involving extended exposure to ambient temperatures below -10°F or above 130°F.
- b. **Lifting of Hazardous Loads.** This hoist is not recommended for use in lifting or transporting hazardous loads or materials which could cause widespread damage if dropped. The lifting of loads which could explode or create chemical or radioactive contamination if dropped requires fail-safe redundant supporting devices which are not incorporated into this hoist.
- c. **Lifting of Guided Loads.** This hoist is not recommended for use in the lifting of guided loads, including dumbwaiters and non-riding elevators. Such applications require additional protective devices which are not incorporated into this hoist. Refer to your state and local regulations governing the requirements for elevator and dumbwaiter installations.

1-6. Warranty

Every hoist is thoroughly inspected and tested prior to shipment from the factory. Should any problems develop, return the complete hoist prepaid to your nearest Coffing Authorized Warranty Repair Station. If inspection reveals that the problem is caused by defective workmanship or material, repairs will be made without charge and the hoist will be returned, transportation prepaid.

This warranty does not apply where: (1) deterioration is caused by normal wear, abuse, improper or inadequate power supply, eccentric or side loading, overloading, chemical or abrasive actions, improper maintenance or excessive heat; (2) problems resulted from repairs, modifications or alterations made by persons other than factory or Coffing Authorized Warranty Repair Station personnel; (3) the hoist has been abused or damaged as a result of an accident; (4) repair parts or accessories other than those supplied by Coffing are used on the hoist. Equipment and accessories not of the seller's manufacture are warranted only to the extent that they are warranted by the manufacturer. EXCEPT AS STATED HEREIN, COFFING MAKES NO OTHER WARRANTIES, EXPRESS OR IMPLIED, INCLUDING WARRANTIES OF MERCHANTABILITY AND FITNESS FOR A PARTICULAR PURPOSE.

SECTION II INSTALLATION

2-1. Safety Notes

- a. Inspect the hoist for any evidence of shipping damage or loose parts.
- b. The supporting structure and load attaching devices should have a load rating at least equal to that of the hoist.
- c. This hoist is not suitable for use in uncovered outdoor locations or areas containing explosive dust, vapors or gases.
- d. The installation area must provide safe operating conditions for the operator, including sufficient room for the operator and other personnel to stand clear of the load at all times.
- e. In areas where slack chain hanging from the hoist may create a hazard, use a chain container (see Figure 2-2).

2-2. Hanging the Hoist

Hook mounted hoists can be used with a variety of trolleys or stationary hangers. It is recommended that a hand-gear or motorized trolley be used when the pulling effort required to move the hoist exceeds 100 pounds or when the application requires frequent movement of the hoist.

- a. Make sure that the hook latch closes after hanging the hoist.
- b. The standard top hook is restrained from rotation by a plate and two screws. The hook can be made to swivel freely by removing the plate, or can be rotated 90° and fixed in that position.
- c. See Figure 2-1 for instructions on adjusting lug-mounted plain trolleys.
- d. Refer to Coffing Motorized Trolley Operating and Maintenance Instructions manual for motorized trolley installation instructions.

2-3. Power Supply Connection

- a. Disconnect power before making connections.
- b. Voltage supplied to the hoist should be within plus or minus 10% of the voltage specified for the hoist. Hoists are tagged at the factory with a tag indicating the voltage for which the hoist is wired. Standard single phase hoists are convertible from 115 to 230 volts. Standard single speed, three phase hoists are convertible from 460 volts to 230 volts. See the Wiring section (paragraph 7-1) for voltage conversion instructions.
- c. National Electrical Code (ANSI C1) and local electrical codes should be consulted and proper disconnects, branch circuit protectors, and wiring provided.
- d. Power cables furnished with the hoist have a green colored ground wire which must be securely connected

to the electrical system ground.

- e. When installing a three-phase hoist, make only temporary connections at the power line. Push the "UP" button and observe the direction of the hook. If it raises, the phasing is correct and permanent connections may be made at the power line. If the load block lowers when the "UP" button is pushed, release the button immediately since the limit switches will not operate to protect the hoist from over-travel. Reverse the red and black wires at the power line connection to correct the hook direction.

CAUTION

Do not change connections in the hoist or the pushbutton assembly.

2-4. Vent Plug

A pressure relief plug (Item 24, Figure 8-2) is provided which will vent excess pressure from the transmission housing.

2-5. Chain Lubrication

The hoist chain should be liberally oiled before placing the hoist into operation. For lubrication instructions, see paragraph 5-6.a.

2-6. Testing

- a. Before placing the hoist into operation, check for proper limit switch operation. Push the "UP" button and verify that the hook block stops at least 2 inches from the bottom of the hoist. Run the hoist down to its lower limit. At least 12 links of chain should remain on the slack end. If either switch is not correct, adjust according to the procedure outlined in paragraph 5-2.

NOTE

The upper and lower limit switches are factory set to provide the maximum allowable hook travel. This travel adjustment should not be increased. However, the switches may be adjusted to stop the hook sooner at either end of its travel.

- b. Attach a light load to the hook and check the hoist for proper operation. The load should stop without noticeable drift when the pushbutton is released. Increase the load to near rated load. The hoist should still lift the load without hesitation and stop with no more than one inch drift.

2-7. Trolley Installation

For Lug Mount and Plain Trolley configurations refer to included manual part number CTA698-1.

For Motorized Trolley configurations refer to included manual part number

2-8. Chain Container Installation

- Operate hoist in “down” direction until it is stopped by the limit switch. Disconnect the slack end of the chain from the hoist by using a small screwdriver to slide the spring-loaded pin to the left. At least 8 inches of chain should hang from the hoist. If less than 8 inches of slack chain is present, readjust lower limit switch using the procedures detailed in paragraph 5-2.
- Slide the spring-loaded pin aside and slip the mounting arm into the slot until the pin fits through the hole in the plate (see Figure 2-2). Be sure pin passes completely through plate and into the opposite housing.
- Use the two hex washer head screws provided to fasten the two remaining hanger chains into the notches on the lower edges of the hoist housings.
- Be sure the end of the chain is started into the container. Run hoist up until the hook block is even with the bottom of the chain container.
- Reset upper limit switch at this position (see procedure, paragraph 5-2) to prevent the possibility of raising a load into the chain container.

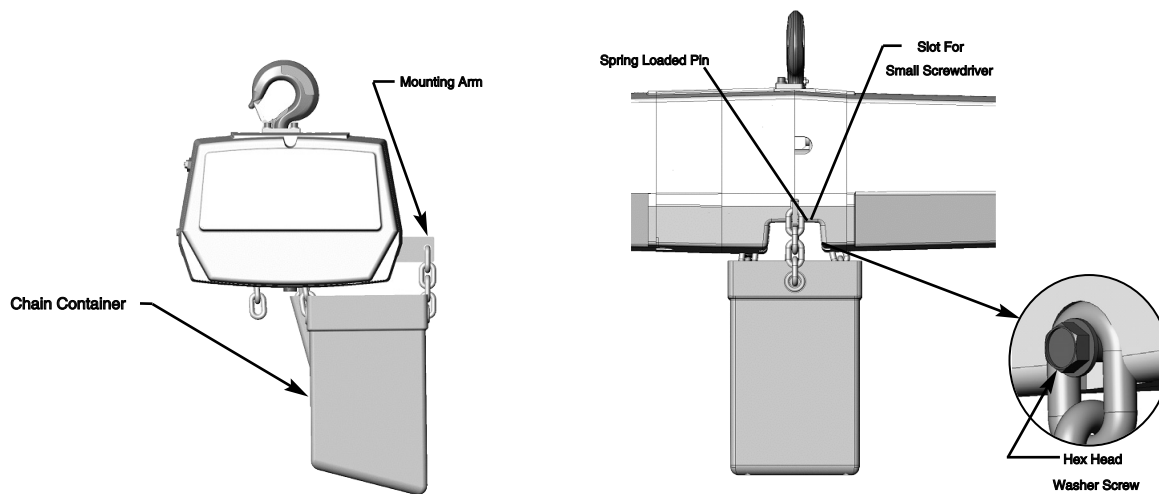

CAUTION

Short edge of chain container body must be mounted toward hoist (as shown).

SECTION III OPERATION

3-1. General

This section presents information concerning the proper operation of the Coffing Electric Chain Hoist. It is not intended to serve as a handbook on rigging. Rigging, the process of moving heavy loads using mechanical devices, requires special knowledge and equipment. For information on the safe use of slings and similar rigging gear, users are urged to consult a textbook on rigging.

3-2. Safety Notes

- Inspect the hoist for any sign of loose, broken, or malfunctioning parts (see Section IV). Any malfunctioning hoist should be tagged as “out of order” and removed from service until the defect is corrected.
- Before starting the hoist, the operator should be certain that all personnel are clear.
- Do not lift more than the rated load of the hoist.
- Do not lift people or loads over people.
- Avoid jogging controls or quick reversals of suspended loads.
- Do not leave a suspended load unattended.

- The operator should have a clear view of the load anytime it is moving and should be sure that the load does not contact any obstructions.
- Read ANSIB30.16 Safety Standard for Overhead Hoists.

3-3. Handling The Load

- Align hoist directly over load. Avoid side pull.
- The hoist chain should not be wrapped around the load. Use proper slings.
- Be sure there are no twists in the load chain as it enters the hoist.

CAUTION

This condition should be constantly checked on double or triple chain hoists because it is possible for the load block to be “capsized” or flipped over one or more times, putting twist in the chain. The presence of twist may not be obvious when the hook block is in the lowered position but can cause serious chain binding when the hook block is in its fully raised position.

- d. Bring the hook into engagement with the load and make sure it is well seated before proceeding to lift the load. On multiple reeved hoists, be sure that the load is equalized on all supporting chains.
- e. Lift the load just clear of its supports and stop the hoist to check for proper brake operation.
- f. Avoid letting the hook or load swing excessively while moving a trolley suspended hoist.

3-4. Overload Limiting Protection

This hoist is equipped with a factory-calibrated overload limiting clutch, which permits lifting loads within rated

capacity and prevents lifting excessive loads which could damage the hoist. If the load exceeds the lifting capability of the overload clutch, the hoist will not lift the load, but the motor will to run as long as the "UP" button is pressed. Repeated attempts to lift an excessive load will overheat the overload clutch and cause permanent damage to the clutch.

CAUTION

The overload limiting clutch is an emergency protection device. It should not routinely be used to measure the maximum load to be lifted.

SECTION IV

INSPECTION

4-1. General

A scheduled inspection routine should be established for this hoist based upon severity of use and environmental conditions. Some inspections should be made frequently (daily to monthly) and others periodically (monthly to yearly). It is suggested that an Inspection and Maintenance Check List and an Inspector's Report similar to those shown in Figures 4-1 and 4-2 be used and filed for reference. All inspections should be made by a designated inspector. Special inspections should be made after any significant repairs or any situation causing suspicion that the hoist may have been damaged. Any hoist which has been removed from service for an extended time should receive an inspection as described under Periodic Inspections. ANSI B30.16, Safety Standard for Overhead Hoists, provides guidelines for hoist operation and inspection.

CAUTION

Any unsafe condition disclosed by any inspection must be corrected before operation of the hoist is resumed.

4-2. Frequent Inspection

- a. Check pushbutton station, brake and limit switches for proper operation.
- b. Check hooks for deformation, chemical damage or cracks. Bent hooks or hooks damaged from chemicals, deformation, cracks or having excessive throat opening (see paragraph 4-6) should be replaced. Visible deformation of any hook may be evidence of hoist abuse and overloading and indicates that a thorough inspection of the complete hoist should be made.
- c. Check that bottom hook swivels freely.
- d. Check for missing, bent or otherwise damaged hook latches.
- e. Check pushbutton and power cord for cuts or other damage.

4-3. Periodic Inspection

The exact period for the following inspections will depend on the anticipated severity of hoist use. Determination of this period should be based on the user's experience. It is recommended that the user begin with a monthly inspection and extend the periods to quarterly, semiannually, or annually, based on his monthly inspection experience.

- a. Clean hoist of any dirt or foreign material. Inspect bottom block for accumulation of debris.
- b. Perform all frequent inspections listed above, c. Check for loose bolts, screws and nuts.
- d. Check housings, load block, and other parts for wear, corrosion, cracks or distortion. Check for abnormal openings between housing sections.
- e. Check motor brake for worn discs, oil contamination or excessive clearance (see paragraph 5-3).
- f. Check mechanical load brake function (see Figure 4-3).
- g. Inspect the entire length of chain for gouges, nicks, weld spatter, corrosion, distortion and wear. See CHAIN INSPECTION, paragraph 4-5.
- h. Inspect hooks and suspension parts for cracks, distortion or extreme wear.
- i. Inspect hooks for cracks using magnetic particle, dye penetrant or other crack detecting methods.
- j. Check limit switch set points and reset if necessary (see paragraph 5-2).
- k. Inspect all wiring for defective insulation, and check to be sure all electrical connections are tight. Check motor reversing contactor or relay for burned contacts.
- l. Inspect for oil leaks. Check oil level.
- m. Inspect for missing or illegible capacity or warning labels.
- n. Inspect the supporting structure for continued ability to support the hoist rated load.

INSPECTION & MAINTENANCE CHECK LIST ELECTRIC POWERED OVERHEAD CHAIN HOIST						
Type of Hoist			Capacity (Tons)			
Location			Original Installation Date			
Manufacturer			Manufacturer's Serial No.			
Item	Frequency of Inspection			Possible Deficiencies	O K	Action Required
	Frequent		Periodic 1-12 Mo			
	Daily	Monthly				
Operating Controls	•	•		Any deficiency causing improper operation		
Limit Switches	•	•		Any deficiency causing improper operation Pitting or deterioration		
Disc (Motor) Brake	•	•		Slippage or excessive wear Glazing, contamination or excessive wear		
Load Brake (Mechanical)				Failure to support load with disc brake open (see paragraph 4-3.f)		
Hooks	•	•	••	Excessive throat opening, bent or twisted more than 10 degrees, damaged hook latch, wear, chemical damage, worn hook bearing Cracks (use dye penetrant, magnetic particle or other suitable detection method)		
Suspension Lug (if used)			••	Cracks, excessive wear or other damage which may impair the strength of the lug Cracks (use dye penetrant, magnetic particle or other suitable detection method)		
Chain	•	•	•	Inadequate lubrication, excessive wear or stretch, cracked, damaged or twisted links, corrosion or foreign substance		
Hook and Suspension UlgConnections			•	Cracks, bending, stripped threads, loose mounting screws.		
Pins, Bearings, Bushings, Shafts Couplings, Chain Guides			•	Excessive wear, corrosion, cracks, distortion		
Nuts, Bolts, Rivets			•	Looseness, stripped and damaged threads. corrosion		
Sheaves			•	Distortion, cracks, and excessive wear Build up of foreign substances		
Housings, Load Block			•	Cracks, distortion, excessive wear Internal build up of foreign substances.		
Wiring and Terminals			•	Fraying, defective insulation		
Contact Block, Magnetic Hoist Control Switch, Other Electrical Apparatus			•	Loose connections, burned or pitted contacts		
Supporting Structure and Trolley (if used)			•	Damage or wear which restricts ability to support imposed loads		
Nameplates, Decals, Warning Labels			•	Missing, damaged or illegible		
Transmission Lubricant			•	Low Level, Requires Changing		

NOTE: Refer to Maintenance and Inspection Sections of the Hoist Maintenance Manual for further details.

FREQUENCY OF INSPECTION:
Frequent — Indicates items requiring inspections daily to monthly Daily inspections may be performed by the operator if properly designated.
Periodic — Indicates items requiring inspection monthly to yearly Inspections to be performed by or under the direction of a properly designated person.
The exact period of inspection will depend on frequency and type of usage. Determination of this period will be based on the user's experience. It is recommended that the user begin with a monthly inspection and extend the periods to quarterly, semi-annually or annually based on his monthly experience.

FIGURE 4-1. RECOMMENDED INSPECTION AND MAINTENANCE CHECK LIST

- b. Inspect each link for wear to the diameter of the link (see Figure 4-4). The nominal link diameter is 0.250 inch for chain on models up to EC-2008 and 0.281 inch for models EC-2012 and above. If the diameter of any link of 0.250 chain is worn to less than 0.200, or the diameter of any link of 0.281 chain is worn to less than 0.225, the entire chain must be replaced.

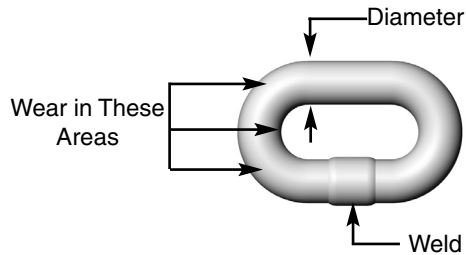

- c. 1.) Check the chain for overall wear or stretch by selecting an unworn, unstretched length of chain (at the slack end, for example). Let the chain hang vertically with a light load (about 20 lbs.) on the chain to pull it taut. Use a large caliper to measure the outside length of a convenient number of links (about 12 inches). Measure the same number of links in a used section of chain and calculate the percentage increase in length of the worn chain.
- 2.) If the length of the worn chain is more than 1 1/2% longer than the unused chain (.015" per inch of chain

measured), then the chain should be replaced. If the chain is worn less than 1 1/2%, check it at several more places along its length. If any section is worn more than 1 1/2%, the chain should be replaced.

- d. The chain used in this hoist is accurately calibrated to operate over the load sprocket and is very carefully heat treated for maximum wear life and strength.

WARNING

1. Do not weld or join hoist load chain.
2. Do not substitute another manufacturer's chain in this hoist.
3. Damage or wear, beyond the stated limits, to any portion of the chain requires that the entire length be replaced.

4-6. Hook Throat Opening

Use Table 4-1 (below) to check hook throat opening.

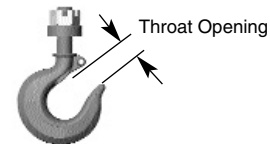

TABLE 4-1. MAXIMUM ALLOWABLE HOOK THROAT OPENING

Hoist Load Rating (ton)	Top Hook* (in.)	Bottom Hook* (in.)
1/4, 1/2 and 1	15/16	13/16
2	15/16	15/16
3	117/32	117/32

*Figures given are for hook with latch. Add 1/16" if measured without hook latch.

**SECTION V
MAINTENANCE AND REPAIR**

5-1. General

This section provides instructions for the most common routine maintenance and adjustments. Major repairs are not within the scope of this manual and should be referred to qualified service facilities.

SAFETY NOTE

Always remove load and disconnect hoist from power supply before removing end covers or making repairs.

5-2. Limit Switch Adjustment

Limit switches are provided to protect the hoist against damage resulting from overtravel. For easy identification the upper (No. 2, Figure 5-1) and lower (No. 3, Figure 5-1) limit switch adjusting nuts are colored brass and zinc respectively. Each limit switch nut has ten slots for adjustment, and the increment of adjustment is such that one slot is equivalent to one link of chain travel. Care should be exercised when adjusting either limit of travel. When a geared type limit switch is furnished (long lift hoists) each adjustment is equal to 3 links of chain, or 30 links per revolution.

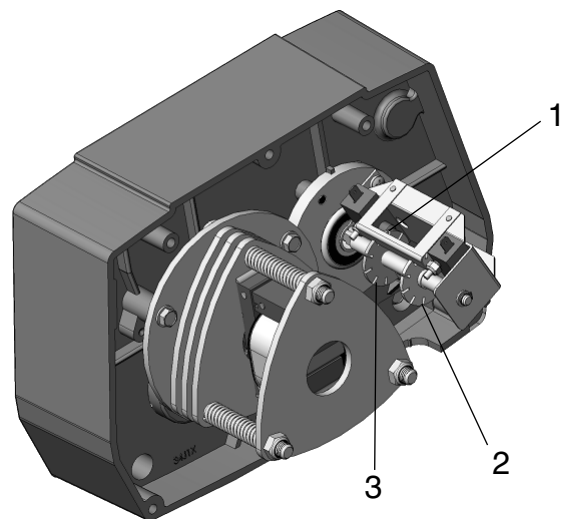

FIGURE 5-1. LIMIT SWITCH ADJUSTMENT

a. Adjusting Upper Limit (Brass Nut).

- 1.) Carefully raise the load block to a point where its top is 2" or more from the hoist housing.
- 2.) DISCONNECT POWER from the hoist and remove the short end cover.
- 3.) With a screwdriver, pry the spring guide plate (No. 1, Figure 5-1) out of the slots in the colored limit switch nuts (Nos. 2 and 3).
- 4.) Turn the slotted brass nut (No. 2) toward its limit switch until the switch clicks.
- 5.) Release the spring guide plate and be sure it snaps back into the slots in both nuts. Do not disturb the other slotted nut if it has been previously set.
- 6.) Replace the short end cover and reconnect power to the hoist.
- 7.) Carefully raise the load block to its upper limit and observe to see if it stops automatically at the desired point. Do not allow the load block to run into the hoist housing. The stopping point should be at least 2" below the hoist housing.

b. Adjusting Lower Limit (Zinc Nut)

- 1.) Carefully lower the load block to a point where at least 12 links of slack chain hang down from the hoist housing.
- 2.) DISCONNECT POWER from the hoist and remove the short end cover.
- 3.) Adjust the zinc limit switch nut in the same manner described above for the brass nut.
- 4.) Replace the short end cover and reconnect power to the hoist.
- 5.) Carefully lower the load block to its lower limit and observe if it stops automatically at the desired level. Do not run chain out of hoist or allow the slack end loop to become taut against the hoist housing. At least 12 links of slack chain should hang from the hoist.

NOTE

If upper and lower limits are not operating satisfactorily, repeat adjustment.

5-3. Motor Brake Adjustment

When properly adjusted, the multiple disc motor brake should release promptly, operate without noticeable chatter, and stop the load with no more than one inch of drift. If the hoist hesitates to lift the load promptly when the pushbutton is depressed, the brake should be adjusted per the following procedure.

- a. Remove any load and DISCONNECT POWER from hoist.
- b. Remove the short end cover.
- c. Referring to Figure 4-2, check the gap between armature (A) and frame (B). The correct gap is .015".
- d. Adjust the gap by turning the three lock nuts (F) and check with a feeler gauge to be sure the gap is the same on both ends of the solenoid.

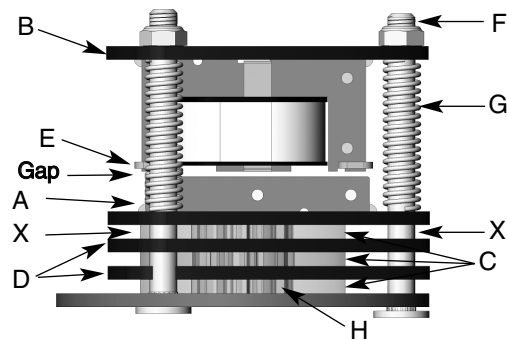

FIGURE 5-2. MOTOR BRAKE ADJUSTMENT

CAUTION

Be sure the bottom of the armature does not touch the splined adapter (H). As wear occurs, the original clearance will be reduced. When this clearance is gone, THE BRAKE DISCS MUST BE REPLACED.

- e. Replace short end cover and reconnect power. If the brake still chatters or is hesitant to release, refer to Section VI, Troubleshooting.

5-4. Top Suspension Removal and Replacement

A number of different top suspension assemblies are available to accommodate different methods of hanging the hoist. If it should be necessary to change top suspensions, proceed as follows:

- a. DISCONNECT POWER from hoist and move the hoist to a safe working area. If necessary, remove trolley and/or rotate suspension lug to gain access to the socket head cap screws bolting the top suspension yoke to the frame of the hoist.
- b. Remove socket head screws (7/16" hex) and lift out the suspension assembly.
- c. Install new suspension assembly and tighten socket head screws to 75 ft-lbs torque.

NOTE

Due to the off-center hook or lug hole, the suspension yoke can be installed in the hoist in two different ways. With the hoist level, the hook or lug must always be directly over the bottom hook. Refer to Figure 5-4 for the proper yoke orientations for single, double and triple chain hoists.

5-5. Chain Replacement (Old chain still in hoist)

Refer to Figure 5-4, Chaining and Suspension Diagrams, and proceed as follows:

- a. Run the load block up to its top limit.
- b. DISCONNECT POWER from the hoist and remove the short end cover.
- c. With a screwdriver, push the spring guide plate (No. 1, Figure 5-1) out of the slots in the limit switch nuts. Turn the brass slotted nut (2) back to about the center of the threaded screw. **DO NOT DISCONNECT THE WIRES FROM THE LIMIT SWITCHES.**

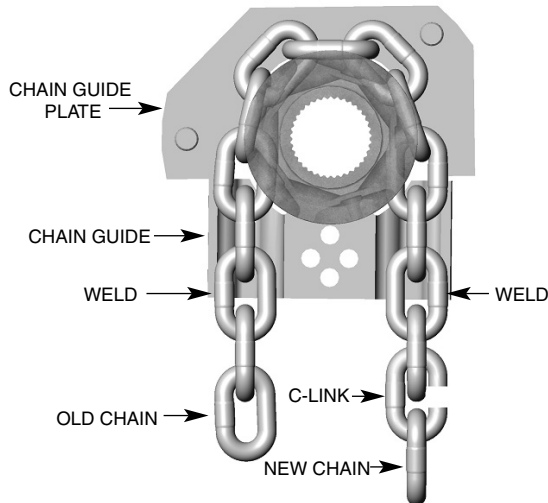

FIGURE 5-3. CHAINING HOIST

- d. Remove the load hook assembly from the old chain.
 - e. Make a “C”-shaped chain link by grinding through one side of the end link of either the old or new chain. See Figure 5-3.
 - f. Hook the special “C” link to the end link of both chains thus joining them. BE SURE the welds of the upstanding links of the new chain are out away from the load sheave, and that proper orientation is observed for attachment of the slack end in paragraph j. below.
- NOTE**
- On triple chain hoists be sure all welds are aligned like the welds on the old chain. It may be necessary to cut a link from one or both ends of the chain to accomplish this.
- g. With the end cover off, connect the hoist to power supply. Be sure the green ground wire is properly grounded.
 - h. Carefully jog the “UP” button and run the joined pieces of chain into the hoist until about 12 inches of the new chain comes out the other side.
 - i. DISCONNECT POWER from the hoist.
 - j. Remove both the “C” link and the old chain from the slack end pin (No. 28, Figure 8-11). This can be accomplished by depressing the pin against the slack end spring (29) with a small screwdriver. Remove the soft split link (23) from the old chain and attach the link to the new chain. Depress the slack end pin and install the split link observing proper orientation of the slack end of the chain when secured. Avoid twists in the chain.
 - k. Adjust the lower limit switch per paragraph 5-2.b.
 - l. Attach the bottom hook on single-chained hoists to the loose end of the chain. On double-chained hoists, feed the loose end of the chain through the load block (welds of the upstanding links will be in towards the sheave) and fasten the end of the chain to the dead end lug (No. 18, Figure 8-11).

NOTE

On triple chain hoists, feed the loose end of the chain through the load block (welds away from sheave), around the idler sheave in the hoist, and to the center of the load block.

- m. Adjust the upper limit switch per paragraph 5-2.a.
- n. Lubricate the new chain per paragraph 5-6.a and perform an operation test of the hoist.

5-6. Lubrication

Proper lubrication is necessary for long, trouble-free hoist operation. Refer to the following and to Table 5-1, Recommended Lubrication Schedule, for lubrication points, type of lubricant, and frequency of lubrication.

- a. **Load Chain** – Clean the load chain with a non-acid and non-caustic solvent and coat with SAE 90 gear oil. Wipe excess oil to prevent dripping. If the hoist is used in an atmosphere containing abrasive dust, the chain should be cleaned and oiled more frequently. Never apply grease to the chain.
- b. **Gearing** – The gear case of the hoist is filled at assembly with 46 oz. of a gear oil containing special friction reducing additives.

WARNING

The use of gear oils other than that recommended in Table 5-1 can cause brake chatter or can render the load brake incapable of holding a load. A 48-oz. container of this oil is available from the Duff-Norton Co. (Part No. 14J1).

- a. **To check the oil level**, remove the 1/8" pipe plug from the side of the hoist. With the hoist hanging level, transmission oil should be even with the edge of the tapped plug hole.
- b. The length of time between necessary oil changes will depend on the severity of use the hoist receives. In general, the oil should be changed every 12 months of normal operation, or every 200 hours of actual hoist on-time. Very heavy use or operation in high ambient temperatures (over 105°F) will require that oil be changed more often. An indication of the need for oil replacement is load brake noise. If an erratic tapping sound is made when lowering a load, the oil should be changed.
- c. **Limit Switch Shaft.** To prevent rust, the threaded limit switch shaft should be given a light coat of grease or be sprayed with a general purpose lubricant.
- d. **Idler Sheave Bearing (double and triple chain models only).** Use a grease gun to put about a teaspoon of grease through the grease fitting in the bottom block shaft. Avoid pumping an excessive amount of grease into the bottom block. On triple chain hoists, use a grease gun to lubricate the idler sheave in the hoist until fresh grease pumps from the end of the sheave bearing.
- e. **Hook Bearing.** Apply a few drops of SAE 30 oil around the edge of the bearing.

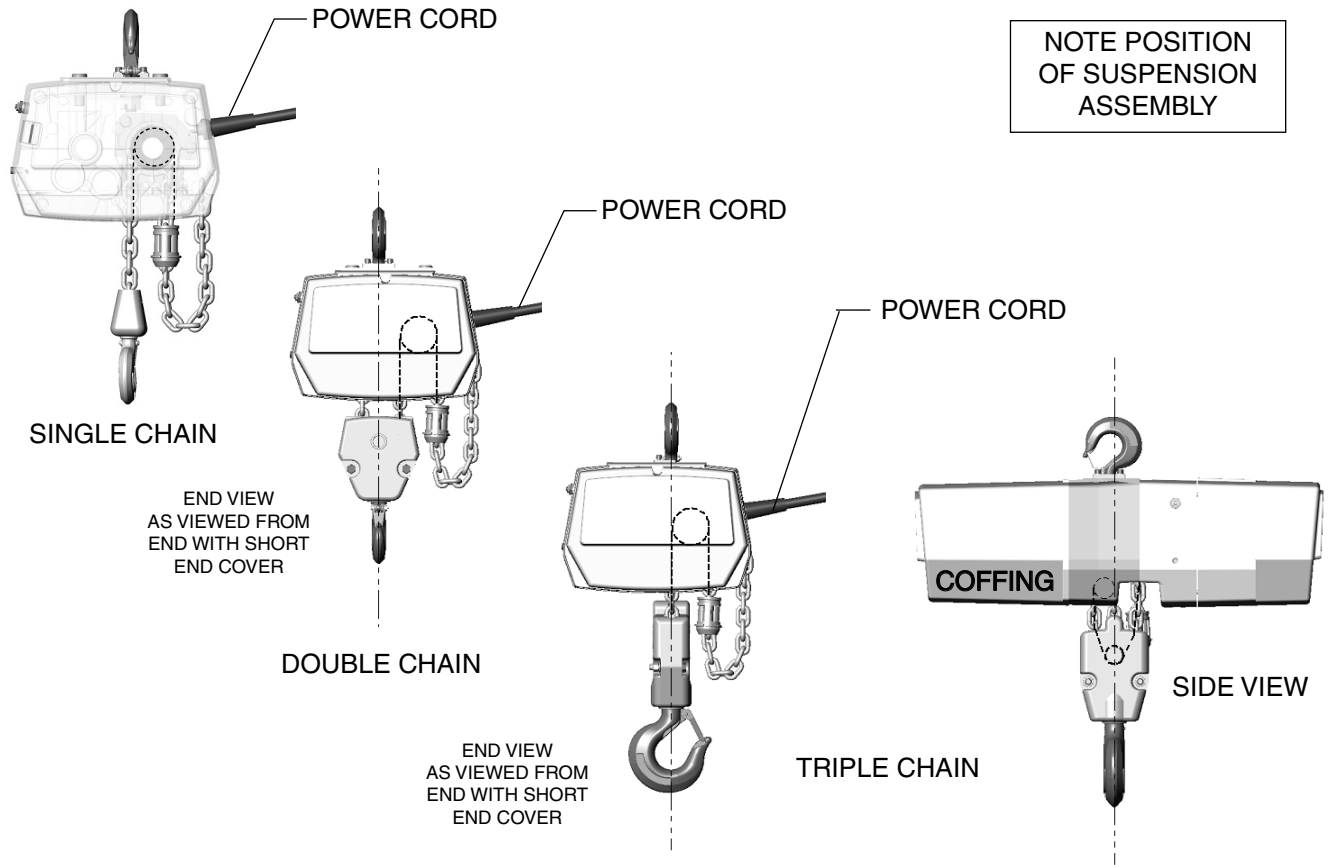

FIGURE 5-4. CHAINING AND SUSPENSION DIAGRAMS

TABLE 5-1. RECOMMENDED LUBRICATION SCHEDULE* MODEL EC ELECTRIC CHAIN HOIST

Figure and Index No.	Component	Type of Lubricant	Type of Service and Frequency of Lubrication		
			Heavy	Normal	Infrequent
Figure 8-6, No. 7	Load Chain	SAE 90 Gear Oil	Daily	Weekly	Monthly
Figure 8-5	Gearing	Coffing No. H-7813 transmission oil (Kit No. 14J1 contains quantity of oil sufficient for one oil change)	At periodic inspection (See Figure 4-1, paragraph 5-6-2)		
Figure 8-8A, No. 9; Figure 8-8B, No. 7	Limit Switch Shaft	“WD-40” or general purpose spray lubricant	Monthly	Yearly	Yearly
Figure 8-6, No. ___ & No. ___	Load Hook Bearing	SAE 30 Gear or Motor Oil	Weekly	Monthly	Yearly
Figure 8-1, Nos. 1, 3, 4 & 5	Top Hook or Suspension Lug Bearing Surfaces	SAE 30 Gear or Motor Oil	Monthly	Yearly	Yearly
Figure 8-10C, No. 11 Figure 8-10D, No. 11	Idler Sheave Bearing (Bushing)	NLGI #2 multi-purpose lithium base grease (Coffing No. H-7610)	At periodic inspection (See Figure 4-1)		

NOTE: All bearings except hook and idler sheave bearings are prelubricated and sealed.

*This lubrication schedule is based on a hoist operating in normal environmental conditions. Hoists operating in adverse atmospheres containing excessive heat, corrosive fumes or vapors, abrasive dust, etc., should be lubricated more frequently.

SECTION VI TROUBLESHOOTING

6-1. General

Use the following table as an aid to troubleshoot your hoist. If you do not have an experienced machinist-electrician to

do your repair work, we recommend that you send your hoist to an approved service center for repairs.

TROUBLE	REMEDY
---------	--------

Hook Fails to Stop at End of Travel.

<ol style="list-style-type: none"> 1. Limit switches not operating. 2. Limit switch nuts not moving on shaft. 3. Magnetic reversing switch malfunction. 	<ol style="list-style-type: none"> 1. Check adjustment. See paragraph 5-2. Check connections against wiring diagram. Tighten loose connections or replace. 2. Check for stripped threads or bent nut guide. 3. Remove electrical cover and check reversing switch.
--	---

Hoist Does Not Respond to Pushbutton.

<ol style="list-style-type: none"> 1. Power failure in supply lines. 2. Wrong voltage or frequency. 3. Improper connections in hoist or pushbutton station. 4. Motor brake does not release. 5. Faulty magnetic hoist control switch. 	<ol style="list-style-type: none"> 1. Check circuit breakers, switches and connections in power supply lines. 2. Check voltage and frequency of power supply against the rating on the nameplate of the hoist. 3. Check all connections at line connectors and on terminal block. Check terminal block on dual-voltage hoists for proper voltage connections. 4. Check connections to the solenoid coil. Check for open or short circuit. Check for proper adjustment. See paragraph 5-3. 5. Check coils for open or short circuit. Check all connections in control circuit. Check for burned contacts. Replace as needed.
--	--

Hook Does Not Stop Promptly.

<ol style="list-style-type: none"> 1. Hoist overloaded. 2. Brake not holding. 	<ol style="list-style-type: none"> 1. Reduce load to within rated capacity of hoist. 2. Check motor brake adjustment (see paragraph 5-3) and load brake (Figure 4-3).
---	---

Hook Moves in Wrong Direction.

<ol style="list-style-type: none"> 1. Three-phase reversal. 2. Improper connections. 	<ol style="list-style-type: none"> 1. Reverse any two wires (except the green ground wire) at the power source (see paragraph 2-3). 2. Check all connections against Wiring Diagram.
--	--

Hoist Hesitates to Lift When Energized.

<ol style="list-style-type: none"> 1. Hoist overloaded. 2. Motor brake requires adjustment. 3. Worn overload limiting clutch. 4. Low voltage. 5. Faulty SINPAC starting switch or start capacitor (single phase hoists only). 	<ol style="list-style-type: none"> 1. Reduce load within rated capacity of hoist. 2. Check motor brake adjustment. See Figure 5-3. 3. Replace clutch. 4. Check voltage at hoist power cord with hoist starting. Voltage should be no less than 90% of voltage specified on hoist. 5. Replace faulty componen
--	---

Hook Raises But Will Not Lower. (Motor not running)

<ol style="list-style-type: none"> 1. "Down" circuit open. 2. Broken conductor in pushbutton cable. 3. Faulty magnetic hoist control switch. 	<ol style="list-style-type: none"> 1. Check circuit for loose connections. Check "Down" limit switch for malfunction. 2. Check each conductor in the cable. If one is broken, replace entire cable. 3. Check coils for open or short circuit. Check all connections in control circuit. Check for burned contacts. Replace as needed.
---	--

TROUBLE	REMEDY
---------	--------

Hook Raises But Will Not Lower When Motor Is Operating.

Consult Factory or Authorized Duff-Norton Warranty Repair Station.

Hook Lowers But Will Not Raise.

<ol style="list-style-type: none"> 1. Hoist overloaded. 2. Low voltage. 3. "UP" circuit open. 4. Broken conductor in pushbutton cable. 5. Faulty magnetic hoist control switch. 6. Faulty capacitor (single-phase hoists only). 7. Worn overload limiting clutch. 	<ol style="list-style-type: none"> 1. Reduce load to within rated capacity. 2. Determine cause of low voltage and bring up to at least 10% of the voltage specified on hoist. Line voltage should be measured while holding or lifting load. 3. Check circuit for loose connections. Check "UP" limit switch for malfunction. 4. Check each conductor in the cable. If one is broken, replace entire cable. 5. Check coils for open or short circuit. Check all connections in control circuit. Check for burned contacts. Replace as needed. 6. Check starting capacitor in motor. Replace if necessary. 7. Replace clutch.
--	---

Lack of Proper Lifting Speed.

<ol style="list-style-type: none"> 1. Hoist overloaded. 2. Motor brake is dragging. 3. Low voltage. 4. Overload limiting clutch intermittently slipping. 	<ol style="list-style-type: none"> 1. Reduce load to within rated capacity of hoist. 2. Check for proper brake adjustment or other defects. See paragraph 5-3. 3. Bring up voltage to plus or minus 10% of voltage specified on hoist. Line voltage should be measured while hoist is lifting load. 4. Replace clutch.
--	--

Load Brake "Noise." (Erratic tapping sounds or squeals)

<ol style="list-style-type: none"> 1. Need transmission oil change, or improper lubricant has been used. 2. Load brake malfunctioning. 	<ol style="list-style-type: none"> 1. Change transmission oil. See Table 5-1. Note: Hoist Warranty is void if unapproved oil is used. 2. Check load brake operation. See Figure 4-3.
--	--

Motor Brake Noise or Chatter. (While starting hoist)

<ol style="list-style-type: none"> 1. Brake needs adjustment. 2. Low voltage. 	<ol style="list-style-type: none"> 1. Adjust as per paragraph 5-3. 2. Check voltage at hoist power cord with hoist starting. Voltage should be no less than 90% of the voltage specified. 115 volt hoists are particularly subject to voltage drop problems due to their high current draw. Conversion to 230 volt operation is suggested in extreme cases.
---	---

Motor Brake "Buzz." (Anytime hoist is running)

<ol style="list-style-type: none"> 1. Brake needs adjustment. 2. Broken shading coil on brake frame. 	<ol style="list-style-type: none"> 1. Adjust as per paragraph 5-3. 2. Replace shading coil or complete brake frame assembly.
--	--

SECTION VII
WIRING

Safety Notes

Disconnect power from hoist before removing end covers.

7-1. Wiring Diagrams

The wiring diagrams for standard hoist models are reproduced on the following pages. In addition, every hoist should have a wiring diagram located inside the long end cover.

7-2. Voltage Conversion

Standard single phase units are convertible from 115 to 230 volts, and standard single speed three phase units are convertible from 460 to 230 volts. Conversion to the alternate voltage can be accomplished with the following procedure.

- a. Be sure power is disconnected from hoist. Remove long end cover.
- b. SINGLE PHASE HOISTS (with SINPAC® switch): Transfer leads per the appropriate terminal block schematic.
- c. THREE PHASE HOISTS: Transfer leads per the appropriate terminal block schematic.

CAUTION

Do not move any wires or make any changes to the wiring except at the terminal block.

- d. After converting voltage, check for proper phasing of three phase units and check for proper limit switch operation.

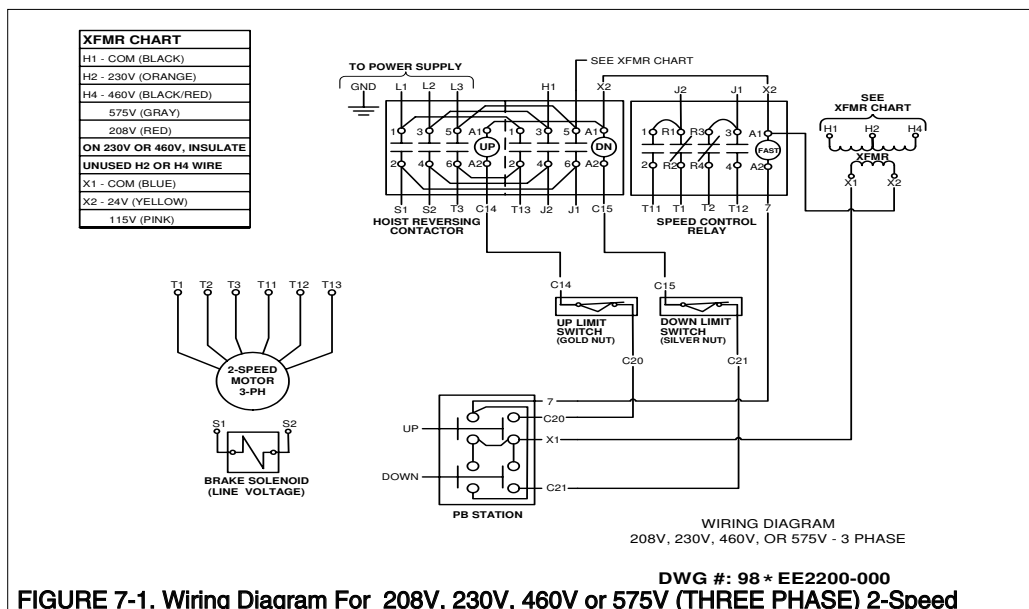
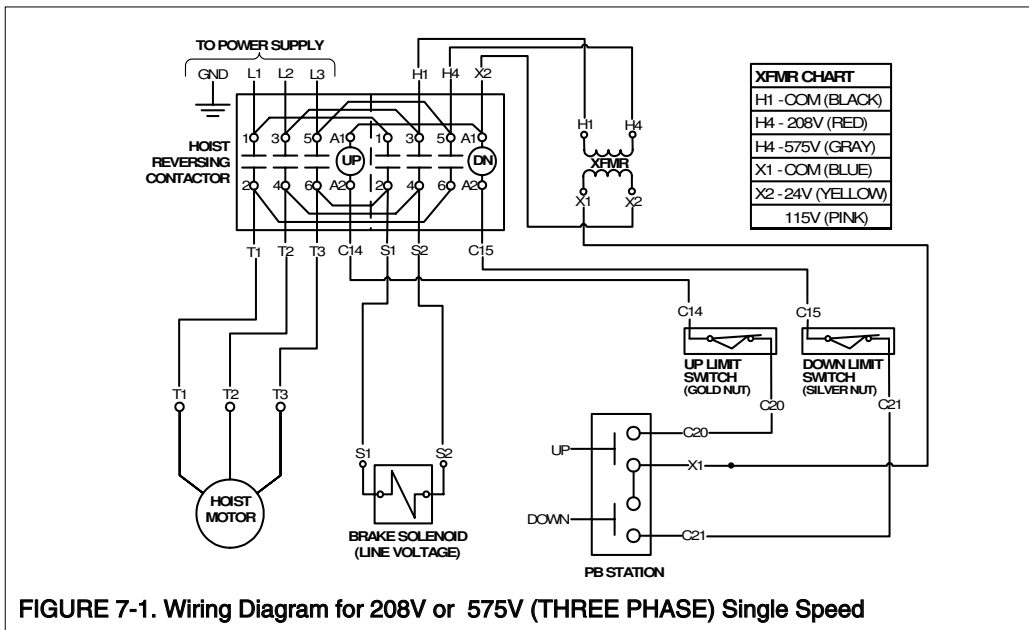

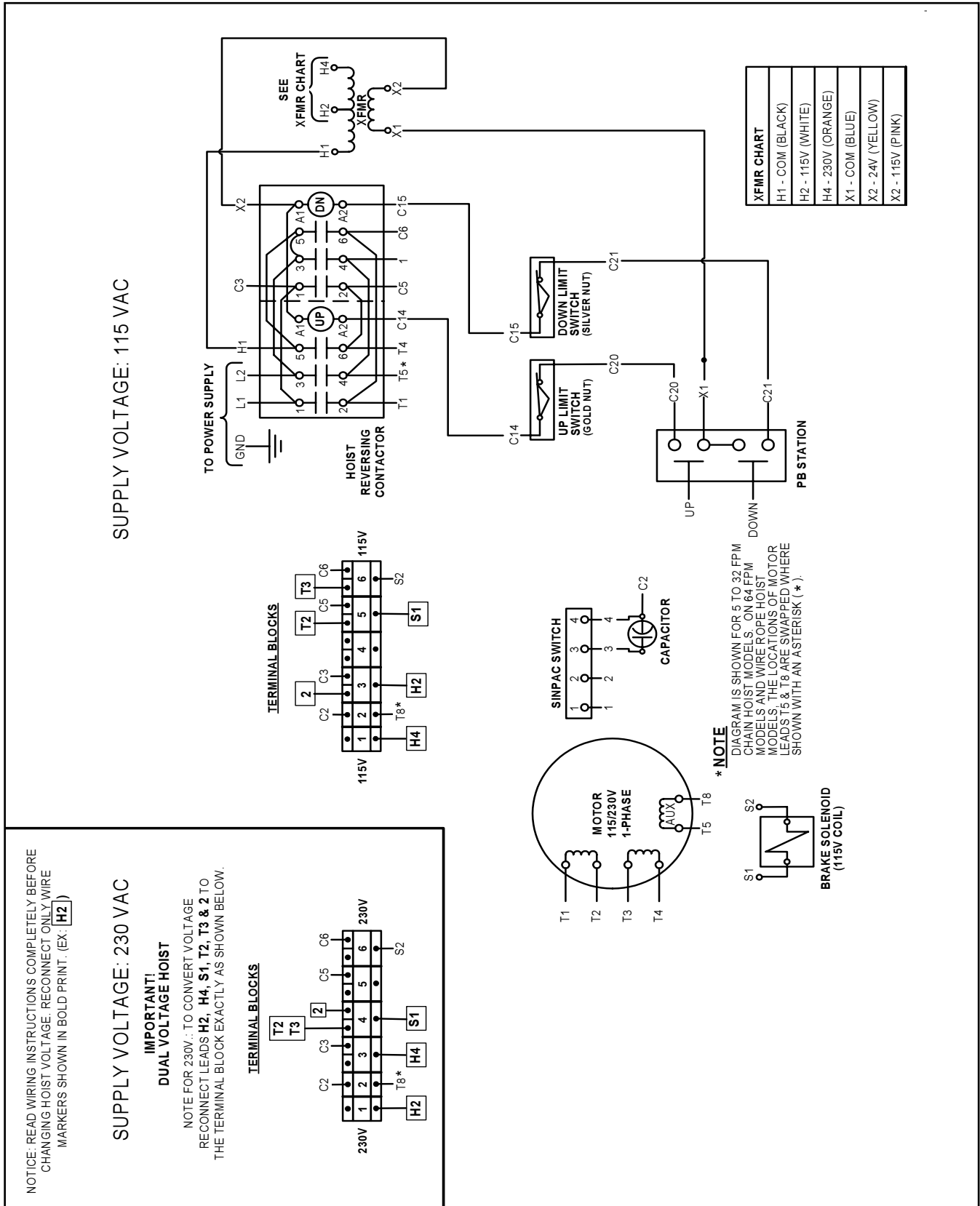

FIGURE 7-2. WIRING DIAGRAM NO. 981EE2100-000 (115/230V, SINGLE PHASE)

NOTICE: READ WIRING INSTRUCTIONS COMPLETELY BEFORE CHANGING HOIST VOLTAGE. RECONNECT ONLY WIRE MARKERS SHOWN IN BOLD PRINT. (EX: **H2**)

SUPPLY VOLTAGE: 230 VAC

IMPORTANT!
DUAL VOLTAGE HOIST

NOTE FOR 230V.: TO CONVERT VOLTAGE RECONNECT LEADS **T7, T8, T9, T5, T6, H4, H2, S1, S2 & T4** TO THE TERMINAL BLOCK EXACTLY AS SHOWN BELOW.

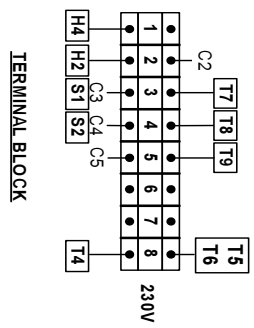

SUPPLY VOLTAGE: 460 VAC

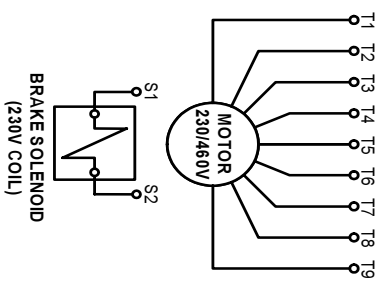
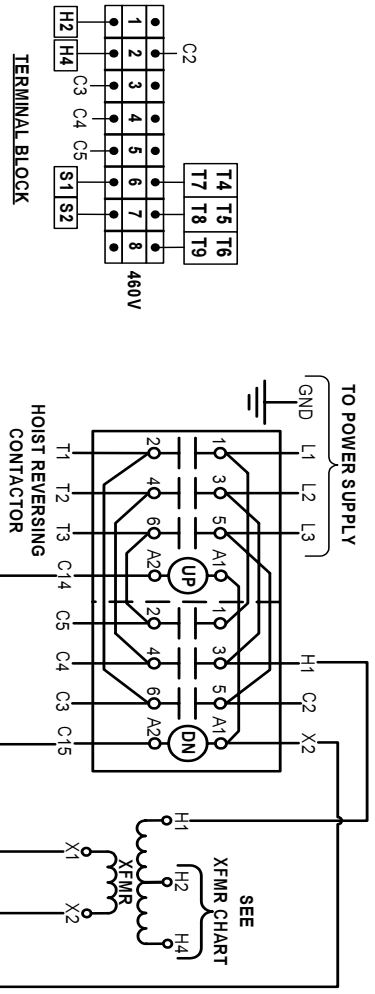

XFMR CHART	
H1 - COM	(BLACK)
H2 - 230V	(ORANGE)
H4 - 460V	(BLACK/RED)
X1 - COM	(BLUE)
X2 - 24V	(YELLOW)
X2 - 115V	(PINK)

FIGURE 7-2. WIRING DIAGRAM NO. 983EE2100-000(230V/ 460V, SINGLE SPEED)

SECTION VIII ILLUSTRATED PARTS LIST

8-1. General

The following exploded drawings provide a complete list of parts used in the standard EC hoist models (shown in Table 1-1, page 3). Since several different models of hoists are covered by this manual, differences may be noted between the appearance of your hoist part and the reference illustration. If this is the case, the parts list will show several different part numbers with sufficient information to allow the selection of the correct part number.

8-2. How to Use the Parts List

a. The parts list consists of four columns as follows:

- 1) Index Number
- 2) Usage Code—This column may contain a code relating to the model numbers of, or other data relating to the hoist in which the part is used. Usage codes are as follows:

- A- Single Phase Hoists (Single Speed)
- B- Three Phase Hoists (Single Speed)
- C- Three Phase Hoists (Two Speed)
- D- Hoists with 1/4 in. Load Chain (Models EC-0516, EC-0532, EC-0564, EC-1009, EC-1016, EC-1032, EC-2004 and EC-2008)
- E- Hoists with 9/32 in. Load Chain (Models EC-2012, EC-2016, EC-4006, EC-4008 and EC-6005)
- F- Single Chain Hoists (Models EC-0516, EC-0532, EC-0564, EC-1009, EC-1016, EC-1032)
- G- Double Chain Hoists (Models EC-2004, EC-2008, EC-4006, EC-4008)
- H- Single Chain Hoists (Models EC-2012, EC-2016)
- J- Triple Chain Hoists (Model EC-6005)

- 3) Part Number
- 4) In addition to basic part name, this column contains descriptions which are essential for choosing the correct part number when more than one is listed.

b. How to determine proper part number:

- 1) Locate the index number in the corresponding figure of the parts list.
- 2) If only one part number is listed for the index number, that part number should be ordered.
- 3) If more than one usage code and part number is listed for that index number, choose the correct usage code by comparing the model number or electrical characteristics of your hoist with the usage codes above.

EXAMPLE A

INDEX NO.	USAGE CODE	PART NO.	PART NAME
6	E	35J1	Transmission Housing
	D	35J2	Transmission Housing

4) If more than one part number is listed with the same usage code, the information under “part name” will determine the correct part number. This is also the case if no usage code is listed and more than one part number is listed for the index number.

EXAMPLE B

INDEX NO.	USAGE CODE	PART NO.	PART NAME
5	B	821- JL -432	Transformer (Pri. 230/460V, Sec. 24V)
		821- JL -431	Transformer (Pri. 230/460V, Sec. 115V)

8-3. How To Order Replacement Parts

When ordering parts or requesting information concerning your EC hoist, always include the hoist model number and serial number. Both numbers are permanently stamped on the transmission housing casting near the chain entrance area. See index No. 6, Figure 8-2 and illustration below.

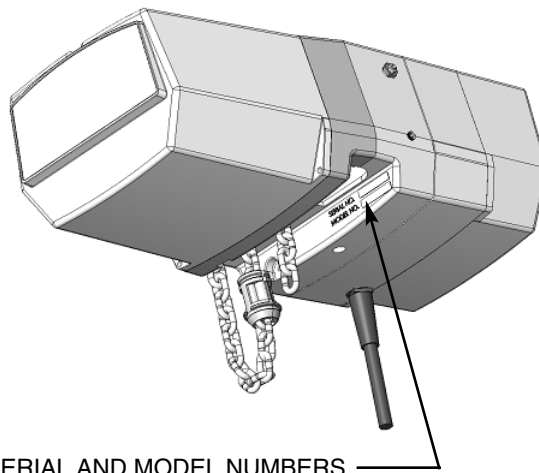

SERIAL AND MODEL NUMBERS

When ordering motor parts, please provide complete motor nameplate data, including motor “ref.” number or model number.

NOTE

Repair parts are available only from Coffing distributors or authorized repair facilities. It is recommended that repair part orders be directed to the authorized repair facility nearest you.

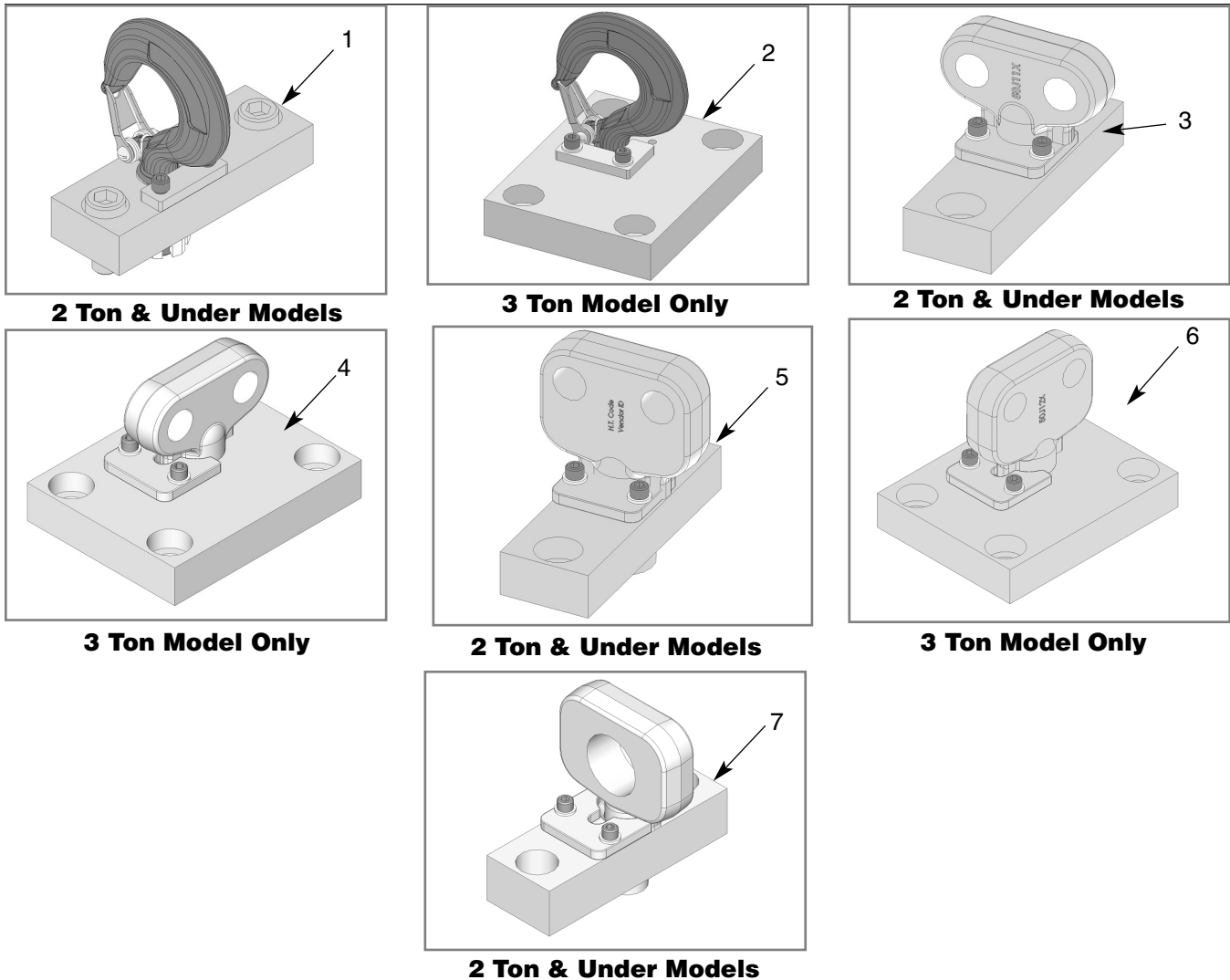

Parts List for Suspension Assemblies

Figure 8-1 - Suspension Assemblies

INDEX NO.	USAGE CODE	PART NO.	PART NAME
1	F,G,H	14J25	Hook Assembly Kit, Swivel
		14J26	Hook Assembly Kit, Rigid
2	J	3JG23	Hook Assembly, Rigid(3-Ton Only)
3	F,G,H	14J3	Trolley Lug Assembly Kit Plain, Geared & Parallel Mounted Motorized Trolley
4	J	50JG53	Trolley Lug Assembly(Plain or Geared Trolley Only)3-Ton Only
5	F,G,H	14J4	Trolley Lug Assembly Kit, Cross Mounted Motorized Trolley
6	J	50JG54	Trolley Lug Assembly, (Motorized Trolley Only) 3-Ton Only
7	F,G,H	50JG22	Multi-Purpose Lug Assembly

INDEX NO.	USEAGE	PART NO.	PART NAME	INDEX NO.	USEAGE	PART NO.	PART NAME
1		36J1	Brake Cover	15		676J2B	Decal, Coffing
2		36J2	Electrical Cover				
3		560J4	Gasket, brake & Electrical Covers	16	A	679J1	Decal, Power Requirements(115/230V)
4		33J1	Sheave Housing (Models EC-2012, EC2016, EC4006 & EC4008)		B	679J2	Decal, Power Requirements (230/460V)
		33J2	Sheave Housing (Models EC0564 & EC1032)		A,B,C	679J3	Decal, Power Requirements (230V)
		33J2-1	Sheave Housing (EC0516, EC0532, EC1009, EC1016, EC2004 & EC2008)		B&C	679J4	Decal, Power Requirements (460V)
	J	33J19	Sheave Housing (Model EC6005)		B&C	679J5	Decal, Power Requirements (575V)
5		34JG1	Transmission Cover (includes 2 oil seals)	20		679J36	Decal, Power Requirements (208V)
6	E	35JG1	Transmission Housing				Suspension Assembly Kit (Ref.#1,3,4 & 5,Figure 8-2)
	D	35JG2	Transmission Housing	21		703J1	Screw(Included in all Suspension Assembly Kits)
7	A	951JL1	Power Cable (1/4 & 1/2 HP)				
	A	952JL1	Power Cable (1 HP)	22		H4086P	Lock Washer (Included in all Suspension Assembly Kits)
	B	953JL1	Power Cable				
8	A&B	940JE1	Wiring Harness				Pushbutton Cable (Ref. Figure 8-10A & 8-10B)
	C	940JE1-36	Wiring Harness	23			
9		H2923P	Screw(slotted hex head)	24A		H6293	Reducer Bushing
		675J2B	Decal, Capacity 1/2 Ton	24B		SK1912-21W	Pressure Relief Plug
		675J3B	Decal, Capacity 1 Ton	25		H2970	Screw
		675J4B	Decal, Capacity 2 Ton	26		S25-13	Level Plug
		675J11	Decal, Capacity 3 Ton	27	F,G,H	4X1305	Latch Kit
11		H4002P	Flat Washer		J	4X1307	Latch Kit (3Ton Only)
12		677J2	Decal, Coffing	28		JF679-1	Tag (230V-1 Phase)
13		H2981P	Screw			JF679-2	Tag (230V-3 Phase)
14		560J5	Gasket, Trans.			JF679-3	Tag (460V-3 Phase)

Contact your nearest Coffing Service Center for parts and service. For a complete list, see pages 34 and 35. Please have the hoist model number, serial number, and part number with description available for reference.

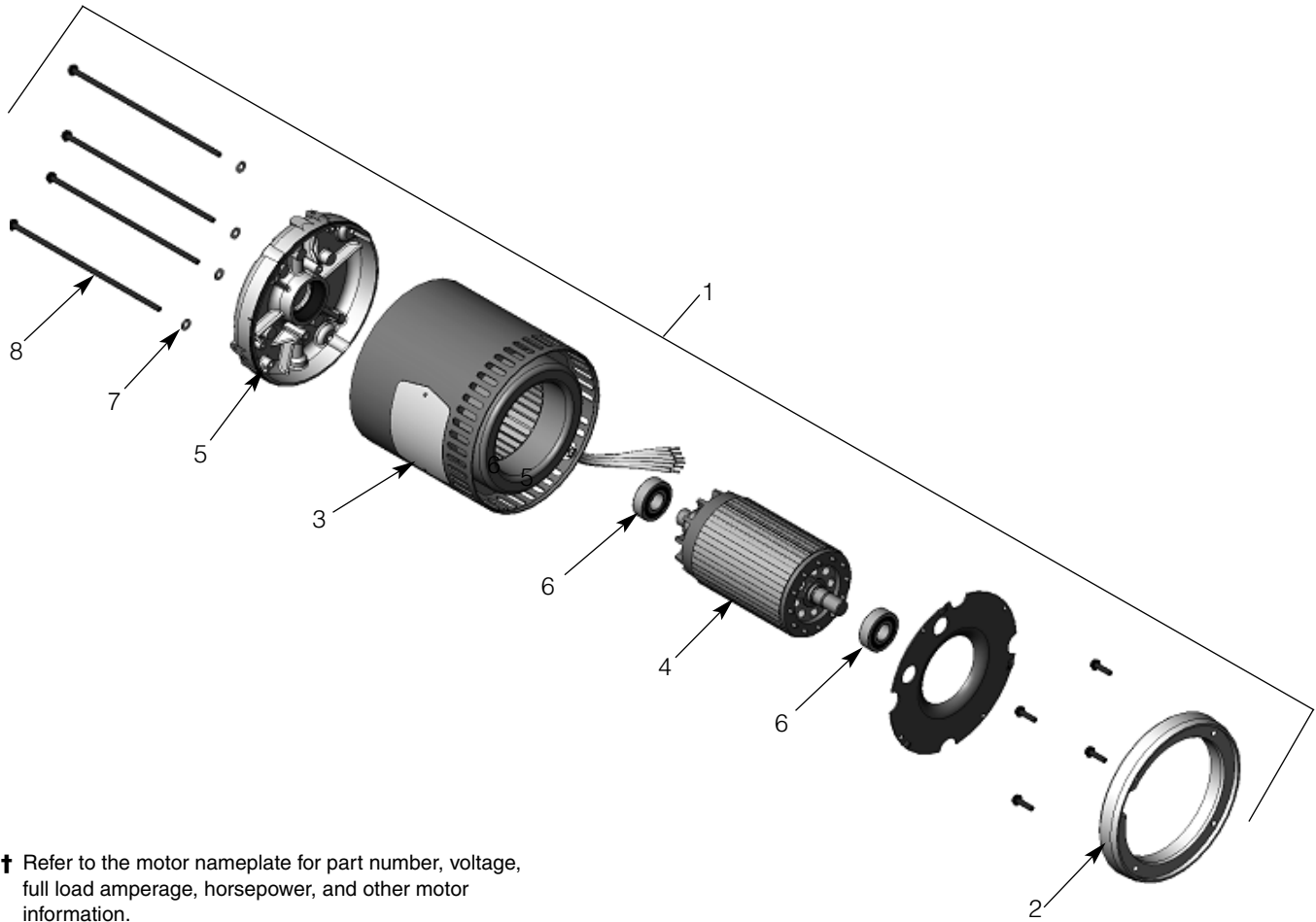

† Refer to the motor nameplate for part number, voltage, full load amperage, horsepower, and other motor information.

Figure 8-3A Motor Parts (One Speed)

Ref. No.	Description	Part No.	Qty.	Ref. No.	Description	Part No.	Qty.
1	Hoist Motor (1-Speed)						
	1/4 hp, 115/230V-1Ph	861J241B	1		1 hp, 208V-3Ph-60Hz	863J149B	1
	1/2 hp, 115/230V-1Ph	861J242B	1		.21 hp, 380V-3Ph-50Hz	863J241B	1
	1 hp, 115/230V-1Ph	861J144B	1		.42 hp, 380V-3Ph-50Hz	863J242B	1
	1/4 hp, 230/460V-3Ph-60Hz	863J241B	1		.83 hp, 380V-3Ph-50Hz	863J144B	1
	1/2 hp, 230/460V-3Ph-60Hz	863J242B	1	2	Adaptor Plate (1HP Only)	*	
	1 hp, 230/460V-3Ph-60Hz	863J144B	1	3	Stator Assembly	*	
	1/4 hp, 575V-3Ph-60Hz	863J244B	1	4	Rotor Assembly	*	
	1/2 hp, 575V-3Ph-60Hz	863J245B	1	5	End Shield	*	
	1 hp, 575V-3Ph-60Hz	863J148B	1	6	Bearing	*	
	1/4 hp, 208V-3Ph-60Hz	863J247B	1	7	Thru Bolt	*	
	1/2 hp, 208V-3Ph-60Hz	863J248B	1	8	#10 Spring Lockwasher	*	

* Not available as an individual part.

Contact your nearest Coffing Service Center for parts and service. For a complete list, see pages 34 and 35. Please have the hoist model number, serial number, and part number with description available for reference.

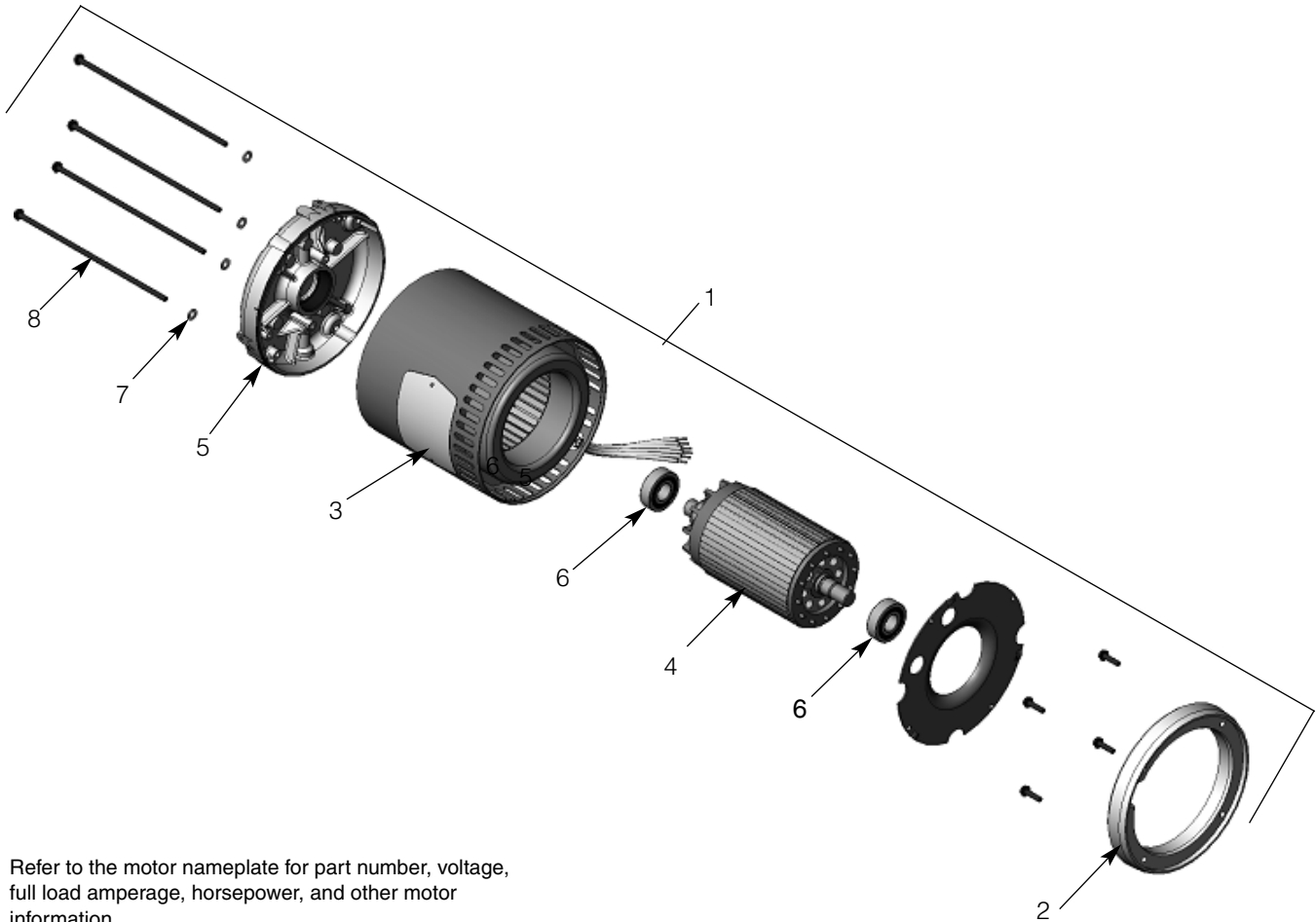

† Refer to the motor nameplate for part number, voltage, full load amperage, horsepower, and other motor information.

Figure 8-3B Motor Parts (Two Speed)

Ref. No.	Description	Part No.	Qty.	Ref. No.	Description	Part No.	Qty.
1	Hoist Motor (2-Speed)				1/4 hp, 208V-3Ph-60Hz	873J251B	1
		873J241B	1		1/2 hp, 208V-3Ph-60Hz	873J249B	1
		873J242B	1		1 hp, 208V-3Ph-60Hz	873J145B	1
		873J144B	1	2	Adaptor Plate (1HP Only)	*	
		873J244B	1	3	Stator Assembly	*	
		873J245B	1	4	Rotor Assembly	*	
		873J148B	1	5	End Shield	*	
		873J247B	1	6	Bearing	*	
		873J248B	1	7	Thru Bolt	*	
		873J152B	1	8	#10 Spring Lockwasher	*	

* Not available as an individual part.

Contact your nearest Coffing Service Center for parts and service. For a complete list, see pages 34 and 35. Please have the hoist model number, serial number, and part number with description available for reference.

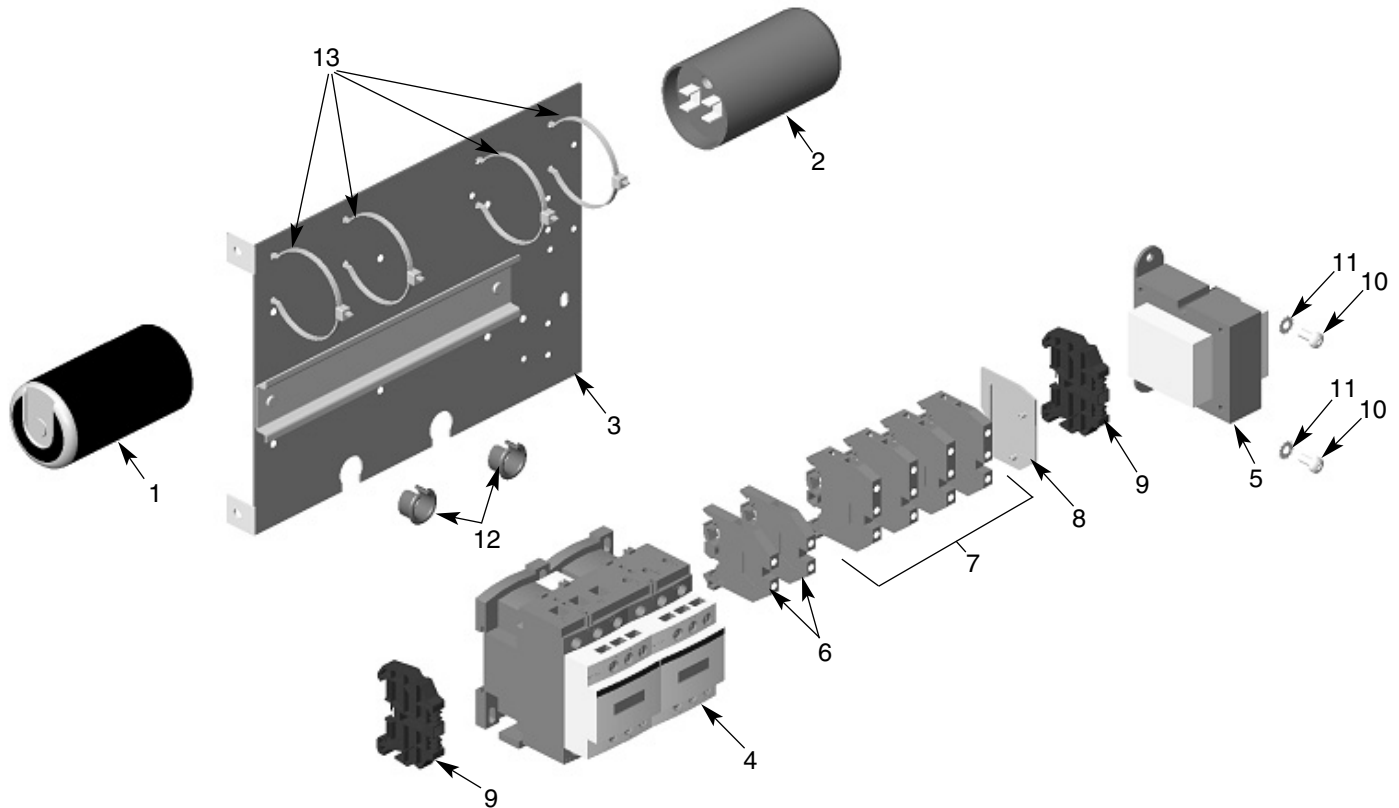

Figure 8-4A Parts List for Electrical Parts for 115/230V - 1-Phase Models

Ref No.	Description	Part No.	Qty	Ref No.	Description	Part No.	Qty
1	Starting Switch	839J3	1	6	Terminal Block	909J10	2
2	Capacitor			7	Terminal Block	909J14	4
	1/4 & 1/2 hp	JL810-3	1	8	End Plate	909J15	1
	1 hp	JL810-4	1	9	End Clamp	909J13	2
3	Panel Plate	257JG200	1	10	8-32UNC X 5/16" Screw	H2751	2
4	Reversing Contactor*			11	#8 External-tooth Lockwasher	H4158	2
	1/4 & 1/2 hp:			12	Grommet	H7956	2
	24V Coil	28860	1	13	Cable Tie	H9006	4
	115V Coil	24799	1	△	15 ft Power Cord Assembly		
	1 hp, 1-Phase:				115/230V, 1/4 & 1/2 hp	951JL1	1
	24V Coil	24791	1		115/230V, 1 hp	952JL1	1
	115V Coil	28905	1				
5	Transformer*						
	Sec.: 24V	821J412	1				
	Sec.: 115V	821J411	1				

* Coil voltage of the contactor and the secondary voltage of the transformer are the same. This is referred to as the control voltage. Standard units are supplied with 24V Control.

△ Not Shown

Contact your nearest Coffing Service Center for parts and service. For a complete list, see pages 34 and 35. Please have the hoist model number, serial number, and part number with description available for reference.

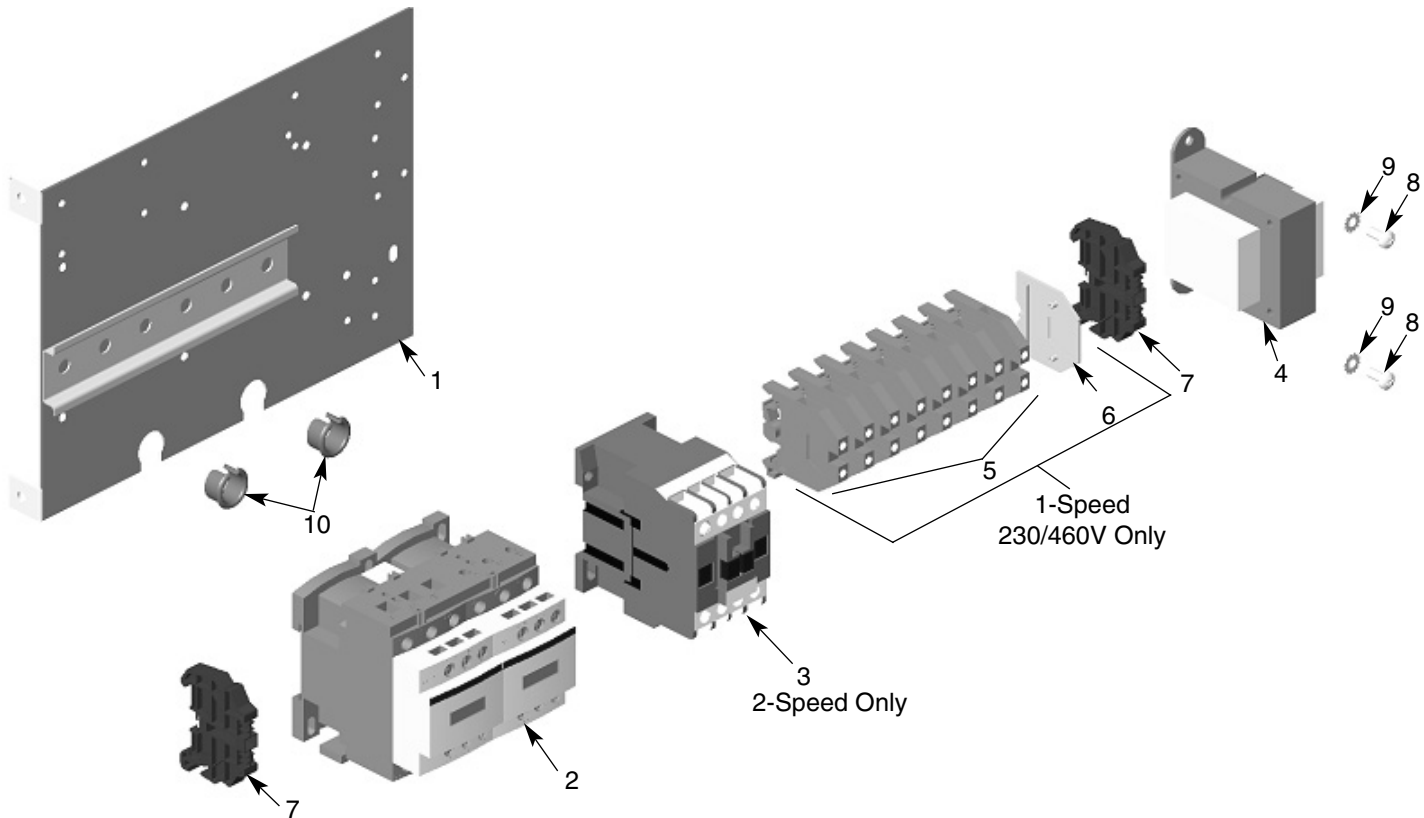

Figure 8-4B Parts List for Electrical Parts for 3-Phase Models

Ref No.	Description	Part No.	Qty	Ref No.	Description	Part No.	Qty
1	Panel Plate	257JG200	1	4	Pri.: 575V, Sec.: 115V	821J451	1
2	Reversing Contactor*				Pri.: 208V, Sec.: 24V	821J472	1
	1/4 & 1/2 hp:				Pri.: 208V, Sec.: 115V	821J471	1
	24V Coil	28860	1		Pri.: 380V, Sec.: 24V	821J482	1
	115V Coil	24799	1		Pri.: 380V, Sec.: 115V	821J481	1
	1 hp :			5	Terminal Block		
	24V Coil	25943	1		230/460V, 1-Speed Models	909J10	8
	115V Coil	24729	1	6	End Plate		
3	Speed Control Relay* (2-Speed Only)				230/460V, 1-Speed Models	909J12	1
	1/4 & 1/2 hp, 24V Coil	28878	1	7	End Clamp	909J13	2
	1/4 & 1/2 hp, 115V Coil	28870	1	8	8-32UNC X 5/16" Screw	H2751	2
	1 hp, 24V Coil	28885	1	9	#8 External-tooth Lockwasher	H4158	2
	1 hp, 115V Coil	28879	1	10	Grommet	H7956	2
4	Transformer*			△	15 ft Power Cord Assembly	953JL1	1
	Pri.: 230/460V, Sec.: 24V	821J432	1				
	Pri.: 230/460V, Sec.: 115V	821J431	1				
	Pri.: 575V, Sec.: 24V	821J452	1				

* Coil voltage of the contactor and the secondary voltage of the transformer are the same. This is referred to as the control voltage. Standard units are supplied with 24V Control.

△ Not Shown

For replacement parts, call 1-800-477-5003
Please have the following information ready:
-Model number
-Serial number (if any)
-Part description and number as shown in parts list

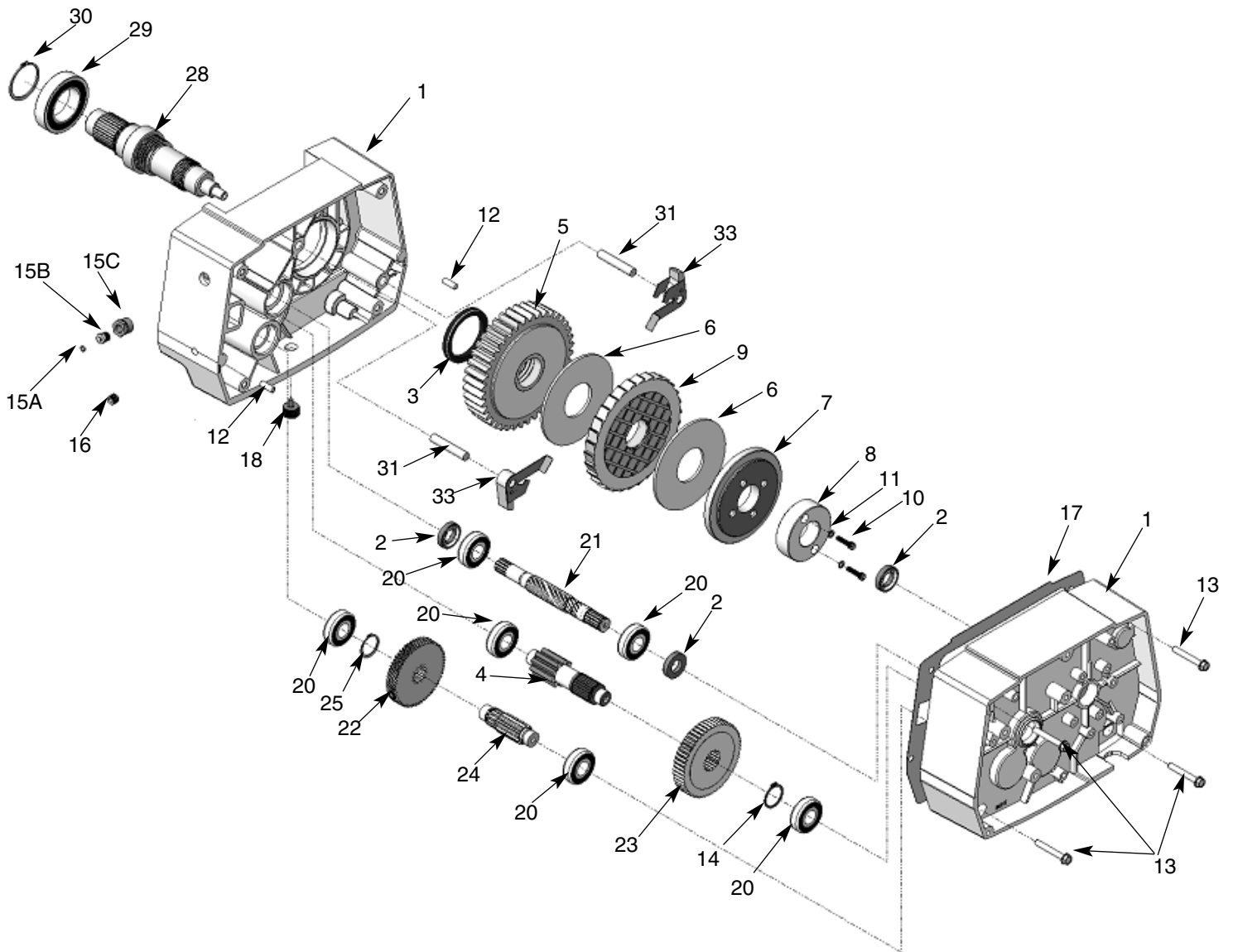

Figure 8-5 Transmission

For replacement parts, call 1-800-477-5003
Please have the following information ready:
-Model number
-Serial number (if any)
-Part description and number as shown in parts list

PARTS LIST FOR TRANSMISSION

INDEX NO.	USAGE CODE	PART NO.	PART NAME
1			Motor, Complete
2		34JG1	Transmission Cover
3		561 K2	Seal
4		MA-562	Seal
5		404J1	Output Pinion
6		407JG25	Output Gear Assembly
7		580J8	Brake Disc (all models except EC-0564)
8		5J6	Pressure Plate
9		130J3	Nut
10		7JG15-1	Ratchet (all models except 0564)
11		7J14	Spacer (EC0564 only)
12		H-2255	Screw
13		H-4133	Lock Washer
14		H-5382	Dowel Pin
15		H-2978-P	Screw
16		H-5503	Retaining Ring
17		H-6258	Fill Plug, Vented
18		S-25-13	Level Plug
19	E	560J5	Gasket (Ref. #14, Figure 7-1)
20	D	H-6268	Drain Plug
21		35JG1	Transmission Housing
		35JG2	Transmission Housing
		500K7	Bearing
		400J1	Input Pinion (Models EC-2012, EC-2016, EC-4006, EC-4008 & EC-6005)
		400J2	Input Pinion (Models EC-0516, EC-1016 & EC-2008)
		400J3	Input Pinion (Models EC-0532 & EC-1032)
		400J4	Input Pinion (Model EC-0564)
		400J9	Input Pinion (Models EC-1009 & EC-2004)
22		401J1	Input Gear (Models EC-2012 & EC-4006)
		401J2	Input Gear (Models EC-0516, EC-1016 & EC-2008)
		401J3	Input Gear (Models EC-0532 & EC-1032)
		401J5	Input Gear (Models EC-2016, EC-4008 & EC-6005)
		401J9	Input Gear (Models EC-1009 & EC-2004)
23		591JG1	Slip Clutch Assembly (Models EC-0516)
		591JG2	Slip Clutch Assembly (Model EC-0532)

INDEX NO.	USAGE CODE	PART NO.	PART NAME
23 (cont.)		591JG3	Slip Clutch Assembly (Model EC-0564)
		591JG4	Slip Clutch Assembly (Models EC-1016 & EC-2008)
		591JG5	Slip Clutch Assembly (Model EC-1032)
		591JG6	Slip Clutch Assembly (Models EC-2012 & EC-4006)
		591JG7	Slip Clutch Assembly (Models EC-2016, EC-4008 & EC-6005)
		591JG20	Slip Clutch Assembly (Model EC-1009 & EC-2004)
24		402J1	Intermediate Pinion (Models EC-2012, EC-4006, EC-1009 & EC-2004)
		402J2	Intermediate Pinion (Models EC-0516, EC-1016, EC-2008, EC-2016, EC-4008 & EC-6005)
		402J3	Intermediate Pinion (Models EC-0532 & EC-1032)
25		H-5549	Retaining Ring (Models EC-0516, EC-1016, EC-2008, EC-2016, EC-4008 & EC-6005)
		H-5553	Retaining Ring (Models EC-2012, EC-4006, EC-1009 & EC-2004)
		H-5530	Retaining Ring (Models EC-0532 & EC-1032)
26		14J1	Transmission Oil Replacement Kit, Includes Oil Required for One Oil Change
28	D	132JG22	Sheave Shaft Assembly
	E	132JG21	Sheave Shaft Assembly
29		500K29	Bearing
30		H-5539	Retaining Ring
31		H-5493	Dowel Pin, Ratchet Ring
32		14J2	Seal Kit, Includes Three 561K2 Seals, One MA-562 Seal and One 560J5 Gasket
33		25JG4-1	Pawl Assembly

Contact your nearest Coffing Service Center for parts and service. For a complete list, see pages 34 and 35. Please have the hoist model number, serial number, and part number with description available for reference.

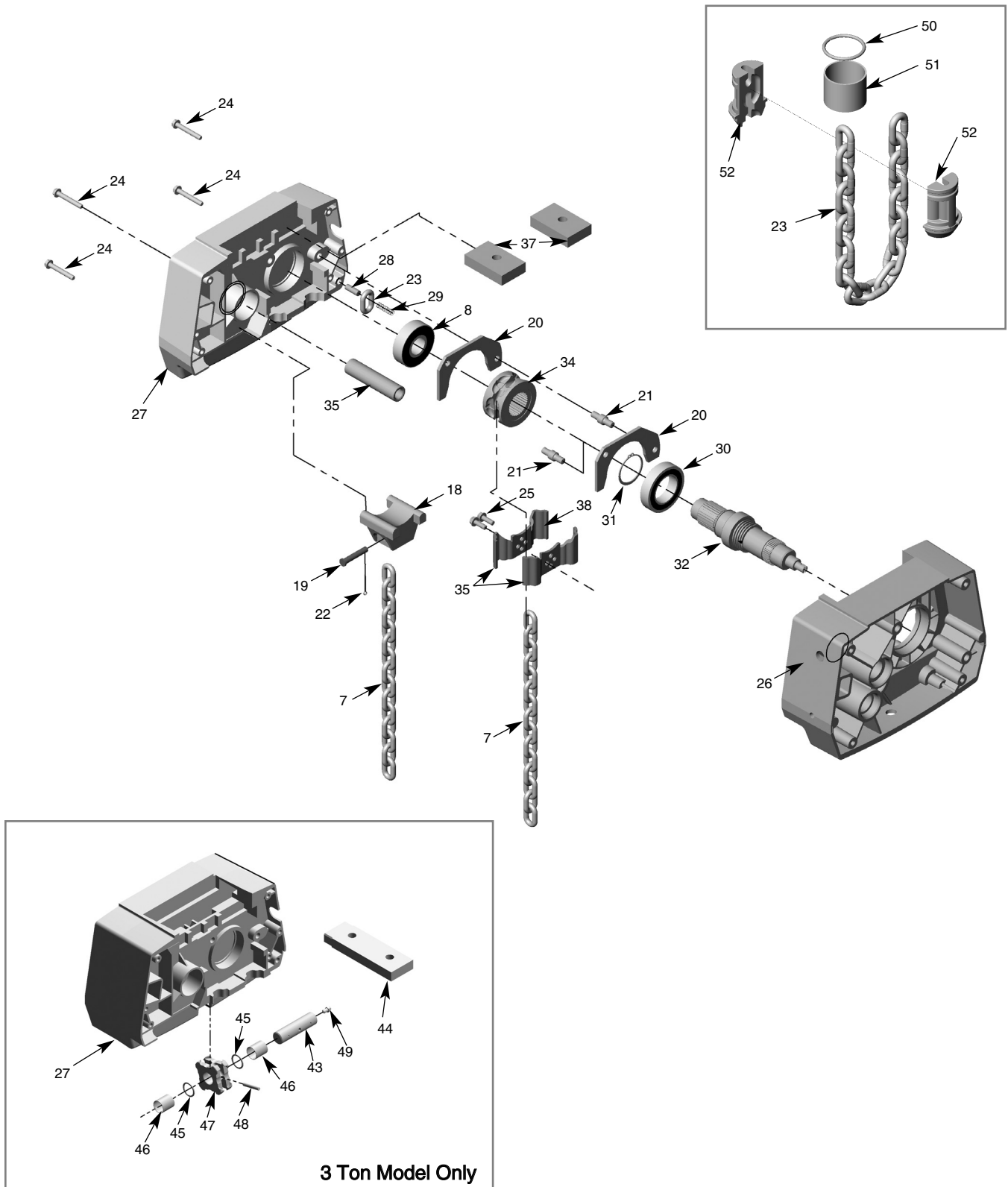

Figure 8-6 Chaming Parts

Contact your nearest Coffing Service Center for parts and service. For a complete list, see pages 34 and 35. Please have the hoist model number, serial number, and part number with description available for reference.

CHAINING PARTS LIST

INDEX NO.	USAGE CODE	PART NO.	PART NAME
6	D	500K28	Bearing
	E	500K5	Bearing
7	D	JL19B	Load Chain (1/4 in. Chain)
	E	JL19-1	Load Chain (9/32 in. Chain)
18	G	4J3	Dead End Lug
19	G	18J1	Dead End Pin
20	E	272J1	Chain Guide Plate (9/32 in. Chain)
	D	272J2	Chain Guide Plate (1/4 in. Chain)
21		127J1	Spacer, Chain Guide Plate
22	G	H-5025-P	Cotter Pin
23		H-7596	Split Chain Link
24	F,G,H	H-2978-P	Screw
	J	H-2232	Screw
25		H-2976-P	Screw
26			Transmission Housing (Ref. #6, Figure 8-2)
27			Sheave Housing (Ref. #4, Figure 8-2)
28		H-5490-P	Pin, Slack End
29		23J2	Spring, Slack End
30		500K29	Bearing (Ref. #29, Figure 8-5)

INDEX NO.	USAGE CODE	PART NO.	PART NAME
31		H-5539	Retaining Ring (Ref. #30, Figure 8-5)
32			Sheave Shaft
34	D	16J2	Sheave (1/4 in. Chain)
	E	16J1	Sheave (9/32 in. Chain)
35	D	JF-250-3	Chain Guide (1/4 in. Chain)
	E	JF-254-3	Chain Guide (9/32 in. Chain)
36	F,G,H	107J1	Drive Coupling
	J	107JG7-4	Drive Coupling
37	F,G,H	170J1	Retainer Block
38		H-5382	Dowel Pin
43	J	122J16	Idler Shaft
44	J	170J4	Retainer Block
45	J	255K31	Washer
46	J	530J35	Sleeve Bearing
47	J	28J12	Idler Sheave
48	J	H-5219	Grooved Pin
49	J	H-7818	Grease Fitting
50	D,E	285J21	Round Wire Retaining Ring
51	D,E	201J3	Sleeve
52 (A)	E	75J6	9/32" End Stop Frame
52 (B)	D	75J7	1/4" End Stop Frame

* Replacement chain is sold by the foot. For single-chained models, add 2 ft to the lift for the total amount of feet. For double-chained models, double the lift and add 3 ft.

Contact your nearest Coffing Service Center for parts and service. For a complete list, see pages 34 and 35. Please have the hoist model number, serial number, and part number with description available for reference.

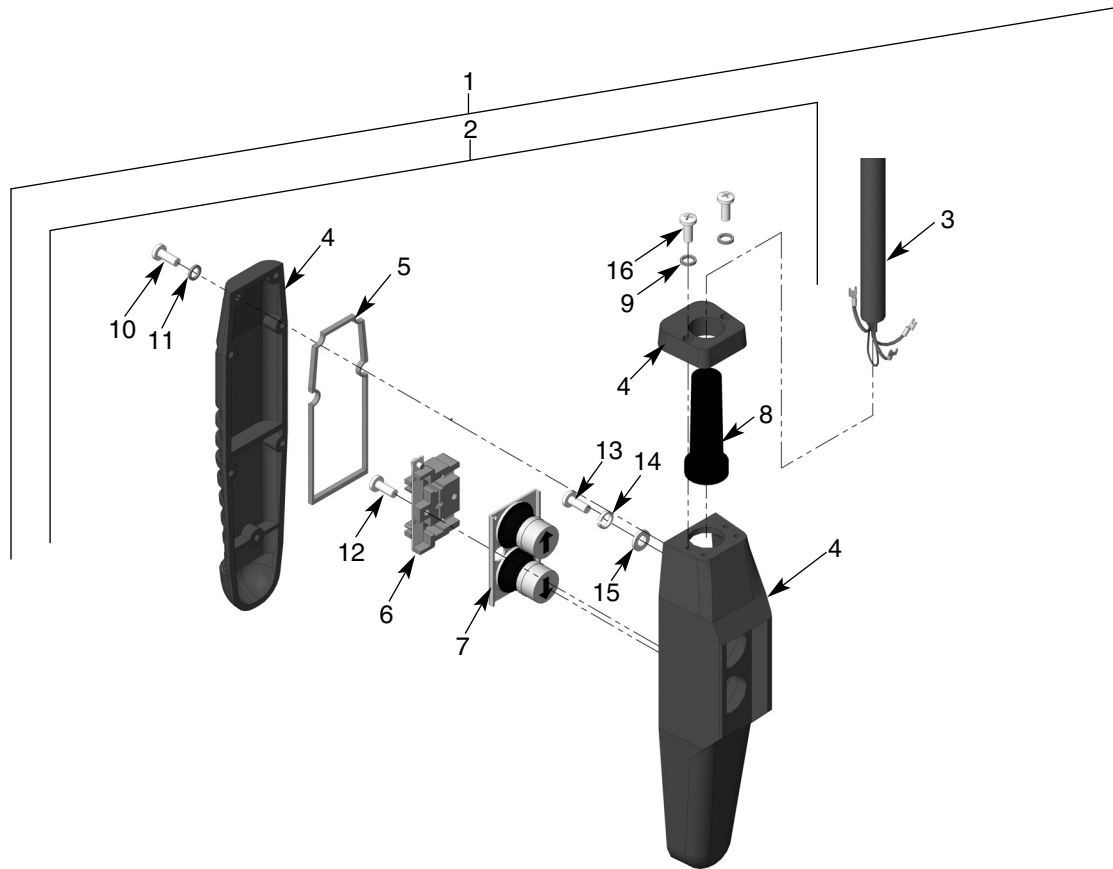

Figure 8-7A Parts List for Pushbutton, 1-Speed

Ref. No.	Description	Part No.	Qty
1	Pushbutton Station & Control Cable Assembly 6 ft Cable Length 11 ft Cable Length 16 ft Cable Length Special Drop	PB2100 6 PB2100-11 PB2100-16 PBS2100-S#	1 1 1 1
2	Pushbutton Station Assembly (2 Button 1-Speed)	36900R	1
3	Control Cable Assembly 6 ft Cable Length 11 ft Cable Length 16 ft Cable Length Special Drop	PBC2100-6 PBC2100-11 PBC2100-16 PBCS2100-S#	1 1 1 1
4	Enclosure	36998R	1
5	Gasket	36986	1
6	Contact Assembly (Includes items 6 & 7 when ordered)	36987	1
7	Button Assembly	36988	1
8	Grommet	36989	1
*	Hardware Kit (Includes items 9 - 16)	36939	1
△	Warning Tag	687K3W	1

(†) Equal to cable length (pushbutton drop).

(△) Not shown.

Contact your nearest Coffing Service Center for parts and service. For a complete list, see pages 34 and 35. Please have the hoist model number, serial number, and part number with description available for reference.

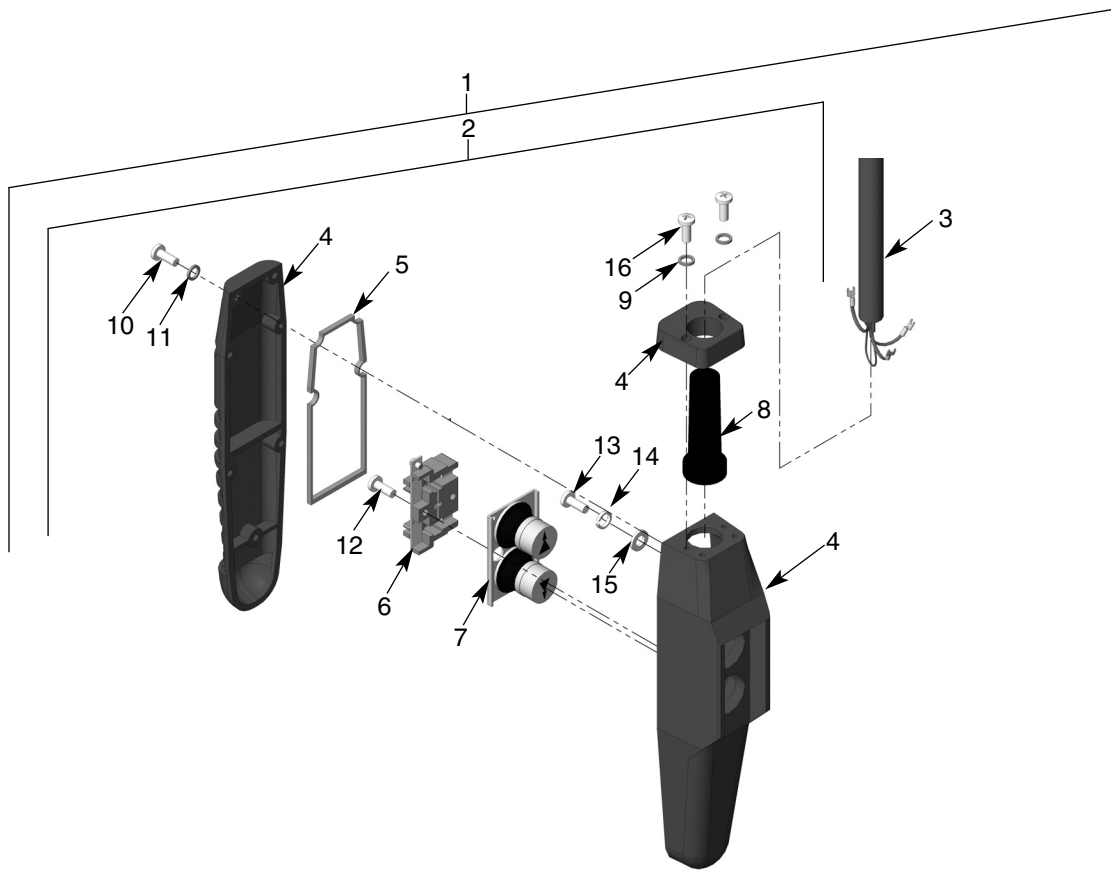

Figure 8-7B Parts List for Pushbutton, 2-Speed

Ref. No.	Description	Part No.	Qty
1	Pushbutton Station & Control Cable Assembly		
	6 ft Cable Length	PB2200-6	1
	11 ft Cable Length	PB2200-11	1
	16 ft Cable Length	PB2200-16	1
	Special Drop	PB2200-S#	1
2	Pushbutton Station Assembly (2 Button 2-Speed)	36800R	1
3	Control Cable Assembly		
	6 ft Cable Length	PBC2200-6	1
	11 ft Cable Length	PBC2200-11	1
	16 ft Cable Length	PBC2200-16	1
	Special Drop	PBC2200-S#	1
4	Enclosure	36998	1
5	Gasket	36986	1
6	Contact Assembly (Includes items 6 & 7 when ordered)	36868	1
7	Button Assembly	36869	1
8	Grommet	36866	1
*	Hardware Kit	36939	1
	(Includes items 9 - 16)		
△	Warning Tag	687K3W	1

(†) Equal to cable length (pushbutton drop).

(△) Not shown.

Contact your nearest Coffing Service Center for parts and service. For a complete list, see pages 34 and 35. Please have the hoist model number, serial number, and part number with description available for reference.

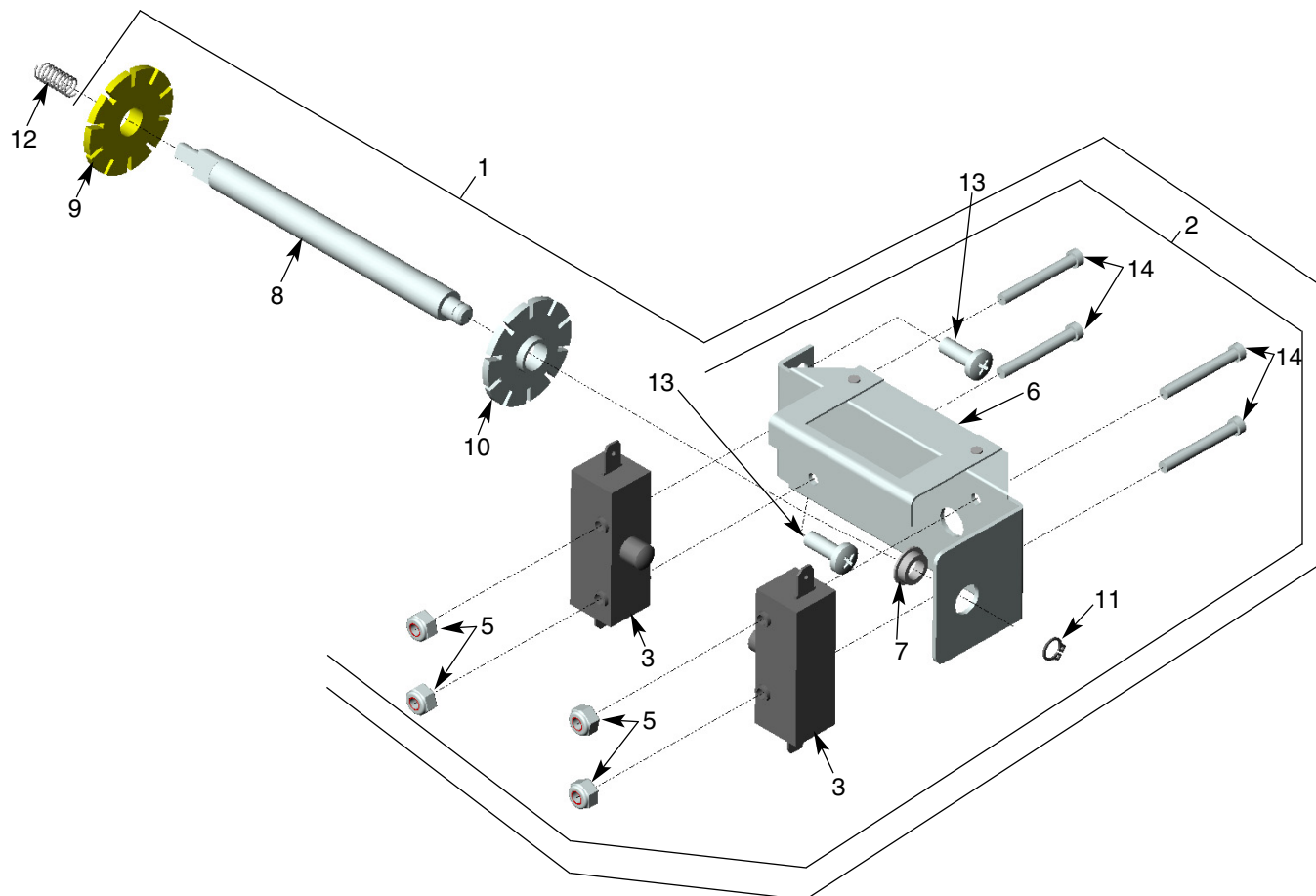
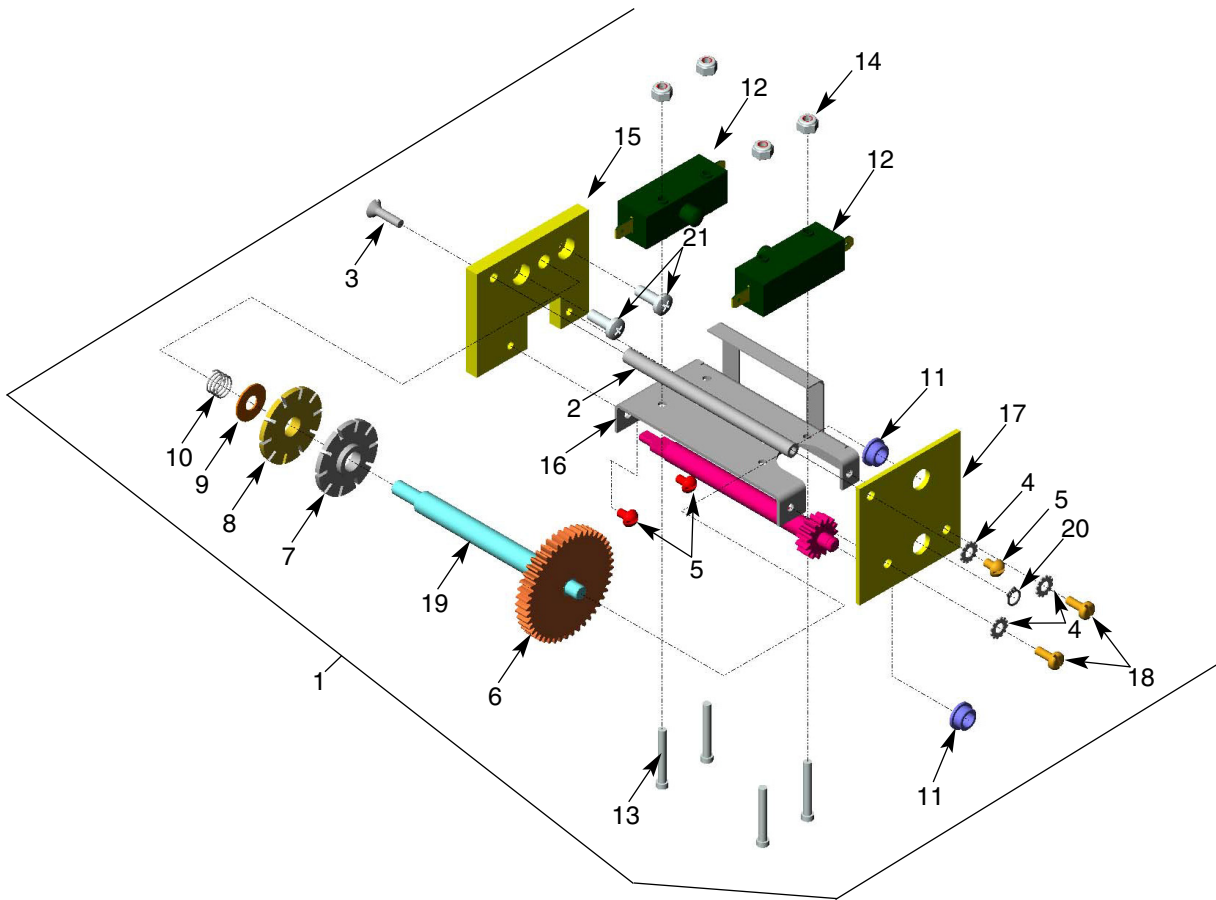

Figure 8-8A Parts List for Limit Switch Assembly

Ref No.	Description	Part No.	Qty	Ref No.	Description	Part No.	Qty
1	Limit Switch Assembly (Includes items 3-11)	918JG4	1	8	Limit Switch Shaft	JF117-3S	1
2	Limit Switch Bracket Assembly (Includes items 3-6)	918JG3	1	9	Limit Switch Nut (silver)	SK6000-63Z	1
3	Switch	815J1	2	10	Limit Switch Nut (gold)	SK6000-63W	1
4	6-32UNC X 1" Screw	H1402P	4	11	Retaining Ring	H5520	1
5	6-32UNC Elastic Locknut	H3944	4	12	Spring	JF343-3	1
6	Limit Switch Bracket (Includes Item 7)	JF900-3	1	13	10-24UNC X 1/2" Screw	H2970	2
7	Bushing	JF531-4	1				

Contact your nearest Coffing Service Center for parts and service. For a complete list, see pages 34 and 35. Please have the hoist model number, serial number, and part number with description available for reference.



Parts 8-8B Parts List for Long Lift Limit Switch Parts

Ref No.	Description	Part No.	Qty	Ref No.	Description	Part No.	Qty
1	Limit Switch Assembly (Includes items 2-20)	944JG6	1	13	6-32UNC X 1" Screw	H1402P	4
2	Post	110J14	1	14	6-32UNC Elastic Locknut	H3944	4
3	8-32UNC X 1/2" Screw	H1210	1	15	Mounting Plate	129J1	1
4	#8 External-tooth Lockwasher	H4158	3	16	Frame and Guide Assembly	258JG7	1
5	8-32UNC X 1/4" Screw	854823	3	17	End Plate	258J8	1
6	Limit Switch Shaft & Gear	117JG2	1	18	8-32UNC X 3/8" Screw	H2741P	2
7	Limit Switch Nut (silver)	SK6000-63Z	1	19	Drive Pinion	427J1	1
8	Limit Switch Nut (gold)	SK6000-63W	1	20	Retaining Ring	H5520	1
9	Thrust Washer	255K16	1	21	10-24UNC X 3/8" Screw	H2981P	2
10	Spring	PB287	1				
11	Bushing	JF531-4	2				
12	Switch	815J1	2				

For replacement parts, call 1-800-477-5003
Please have the following information ready:
-Model number
-Serial number (if any)
-Part description and number as shown in parts list

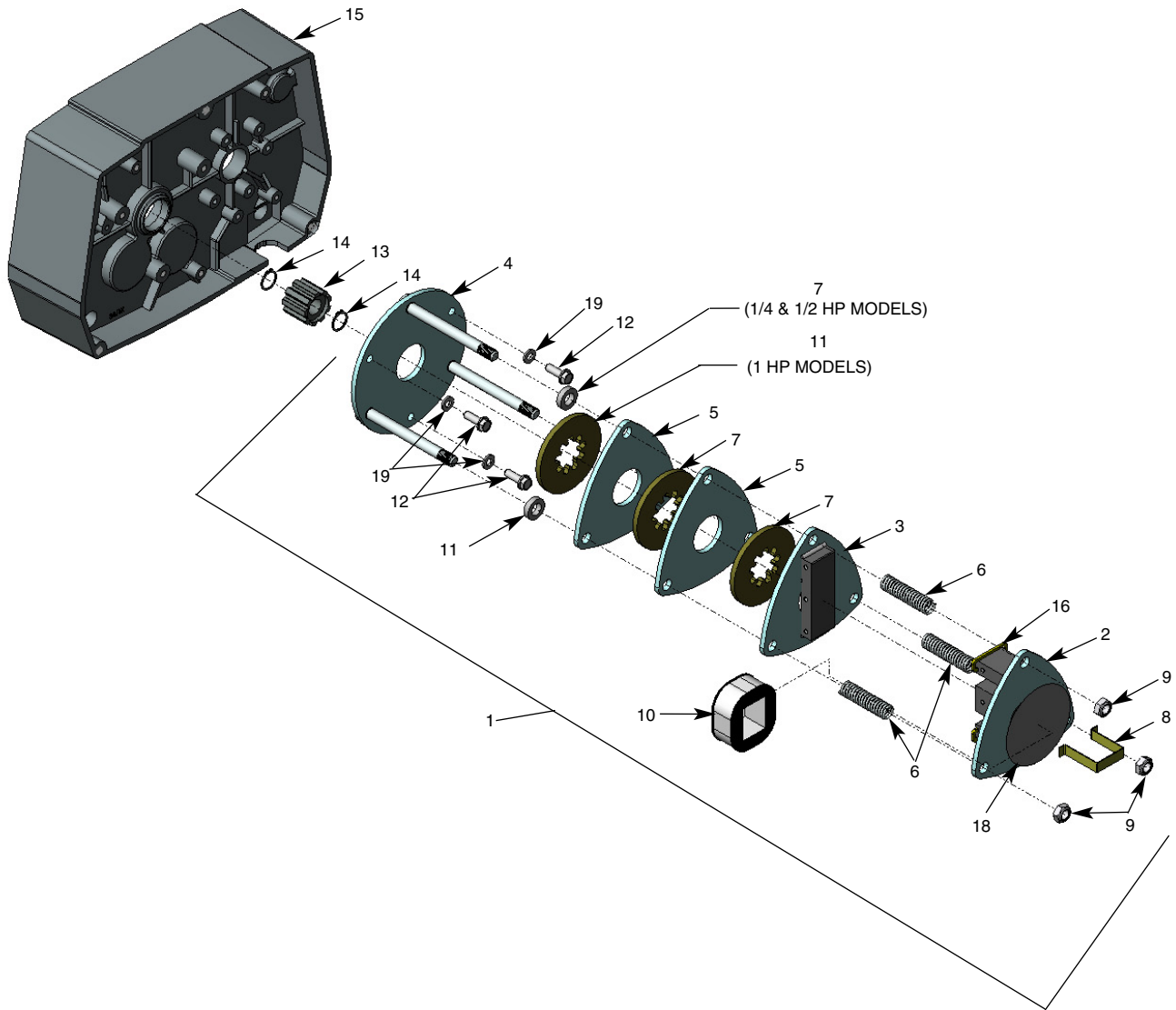

Figure 8-9 Motor Brake Parts

For replacement parts, call 1-800-477-5003
 Please have the following information ready:
 -Model number
 -Serial number (if any)
 -Part description and number as shown in parts list

MOTOR BRAKE PARTS LIST

INDEX NO.	USAGE CODE	PART NO.	PART NAME
1	A	854JG6	Disc Brake Assembly (1/4 & 1/2 HP, 115/230 V Hoists)
	A	854JG1	Disc Brake Assembly (3/4 & 1 HP, 115/230 V Hoists)
	B	854JG7	Disc Brake Assembly (1/4 & 1/2 HP, 230/460 V Hoists)
	B	854JG2	Disc Brake Assembly (3/4 & 1 HP, 230/460 V Hoists)
	C	854JG7	Disc Brake Assembly (1/4 & 1/2HP, 230V Hoists)
	C	854JG2	Disc Brake Assembly (3/4 & 1 HP, 230 V Hoists)
	C	854JG8	Disc Brake Assembly (1/4 & 1/2 HP, 460 V Hoists)
	C	854JG3	Disc Brake Assembly (3/4 & 1 HP, 460 V Hoists)
	B,C	854JG9	Disc Brake Assembly (1/4 & 1/2 HP, 575 V Hoists)
	B,C	854JG4	Disc Brake Assembly (3/4 & 1 HP, 575 V Hoists)
	B,C	854JG10	Disc Brake Assembly (1/4 & 1/2 HP, 208 V Hoists)
	B,C	854JG5	Disc Brake Assembly (3/4 & 1 HP, 208 V Hoists)
2		857JG1	Plate and Frame Assembly
3		858JG1	Plate and Armature Assembly

INDEX NO.	USAGE CODE	PART NO.	PART NAME
4		859JG1	Plate and Stud Assembly
5		291J1	Brake Plate
6		JF-344	Spring
7		581J1A	Brake Disc
8		JF-710	Retainer
9		H-3978	Locking Nut
10	A	JF-853-1	Coil (115 V, 60 Hz, For Brake 854JG6, 854JG1)
	B&C	JF-853-2	Coil (230 V, 60 Hz, For Brake 854JG7, 854JG2)
	C	JF-853-3	Coil (460 V, 60 Hz, For Brake 854JG8, 854JG3)
	B&C	JF-853-4	Coil (575 V, 60 Hz, For Brake 854JG9, 854JG4)
	B&C	JF-853-5	Coil (208 V, 60 Hz, For Brake 854JG10, 854JG5)
11		141J2	Spacer (1/4 & 1/2 HP models only)
12		H-2976-P	Screw
13		142J1	Brake Adapter
14		H-5501	Retaining Ring
15		34JG1	Transmission Cover (Ref #5, Figure 8-1)
16		860J1	Shading Coil Element (Must be attached to frame with H-7812 Adhesive)
17		H-7812	Adhesive (1-oz. Tube)
18		676J1	Decal, Load Equalizer
19		H-4134	Lock Washer

For replacement parts, call 1-800-477-5003
 Please have the following information ready:
 -Model number
 -Serial number (if any)
 -Part description and number as shown in parts list

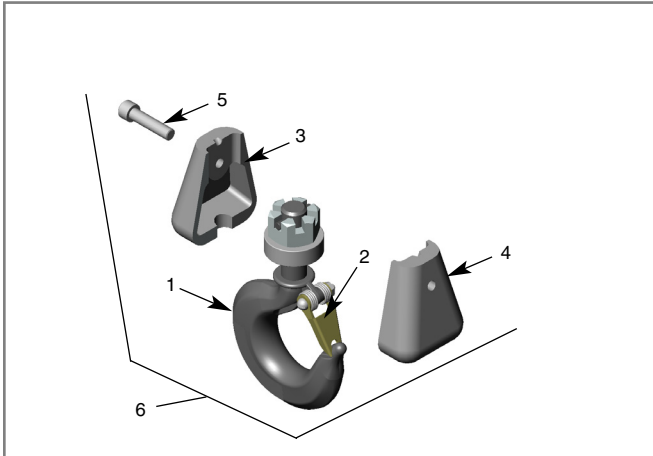

Figure 8-10A. (1/4 Ton & 1/2 Ton Models)

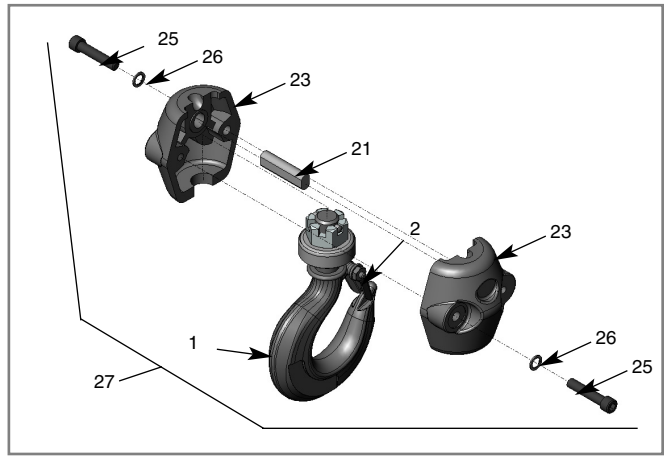

Figure 8-10B. (1Ton Models)

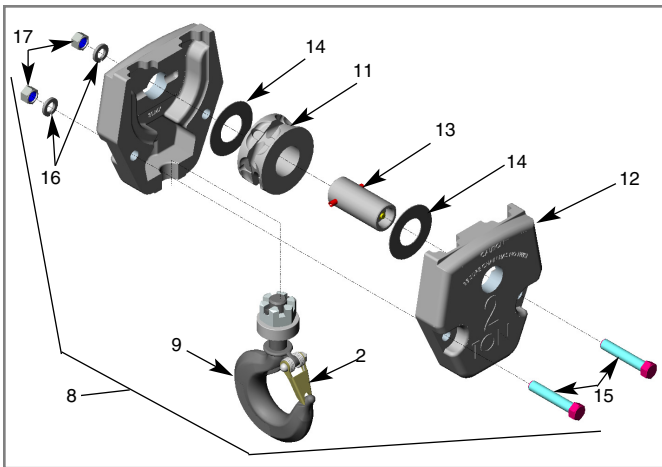

Figure 8-10C. (Double Chain Models)

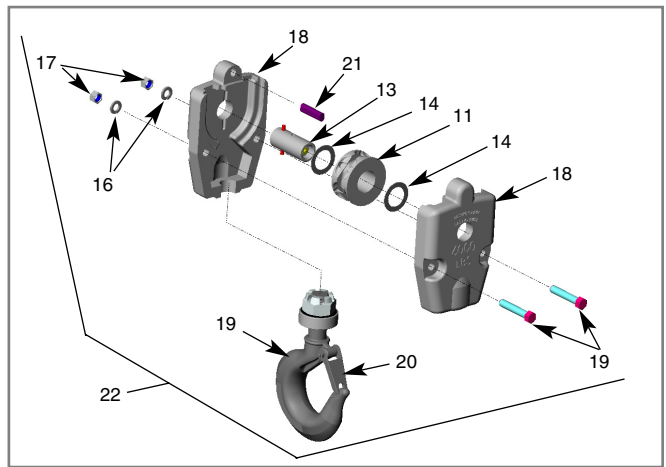

Figure 8-10D. (Triple-Chain Models) 3 Ton Only

Parts List for Bottom Block Assemblies

Index No.	Usage Code	Part No.	Part Name
1	F,H	3JG20S	Hook & Latch Assembly
2	F,H	4X1304	Latch Kit
3	F	JF20-2	Load Block Frame
4	F	JF20-3	Load Block Frame
5	F	JF700	Screw
6	F	913JG4AS	Bottom Block Assembly
8	G	914JG2	Bottom Block Assembly (Models EC2004 & EC2008)
	G	914JG4	Bottom Block Assembly (Models EC4006 & EC4008)
9	G	3KG1	Hook & Latch Assembly (Models EC4006 & EC4008)
	G	3KG6	Hook & Latch Assembly (Models EC2004 & EC2008)
11	G	16JG7	Sheave & Bearing Assembly (Models EC2004 & EC2008)
	G,J	16JG6	Sheave & Bearing Assembly (Models EC4006, EC4008 & EC6005)

Index No.	Usage Code	Part No.	Part Name
12	G	30J2	Frame (Models EC2004 & EC2008)
	G	30J4	Frame (Models EC4006 & EC4008)
13	G,J	122JG3	Shaft Assembly
14	G,J	255K2	Washer
15	G,J	H2403P	Screw
16	G,J	H4085p	Lock Washer
17	G	H3473P	Hex Nut
	J	H3964P	Hex Nut
18	J	30J20	Frame
19	J	3JG14S	Hook & Latch Assembly
20	J	4X1307	Latch Kit
21	J	18J8	Dead End Pin
22	J	914JG23	Bottom Block Assembly
23	H	30J14	Frame
25	H	S49-77	Screw
26	H	H4134	Lock Washer
27	H	913JG3AS	Bottom Block Assembly

For replacement parts, call 1-800-477-5003
 Please have the following information ready:
 -Model number
 -Serial number (if any)
 -Part description and number as shown in parts list

Index No.	Part No.	Part Name	Index No.	Part No.	Part Name
1	927JG17	Chain Container Kit (20 Feet chain max.)		927J18	Container (25 Feet chain max.)
	927JG18	Chain Container Kit (25 Feet chain max.)		927J19	Container (35 Feet chain max.)
	927JG19	Chain Container Kit (35 Feet chain max.)		927J20	Container (50 Feet chain max.)
	927JG20	Chain Container Kit (50 Feet chain max.)	3	267J3	Mounting Arm
2	927J17	Container (20 Feet chain max.)	4	53J4	Chain Section
			5	H7929	Split Link
			6	H2349	Screw

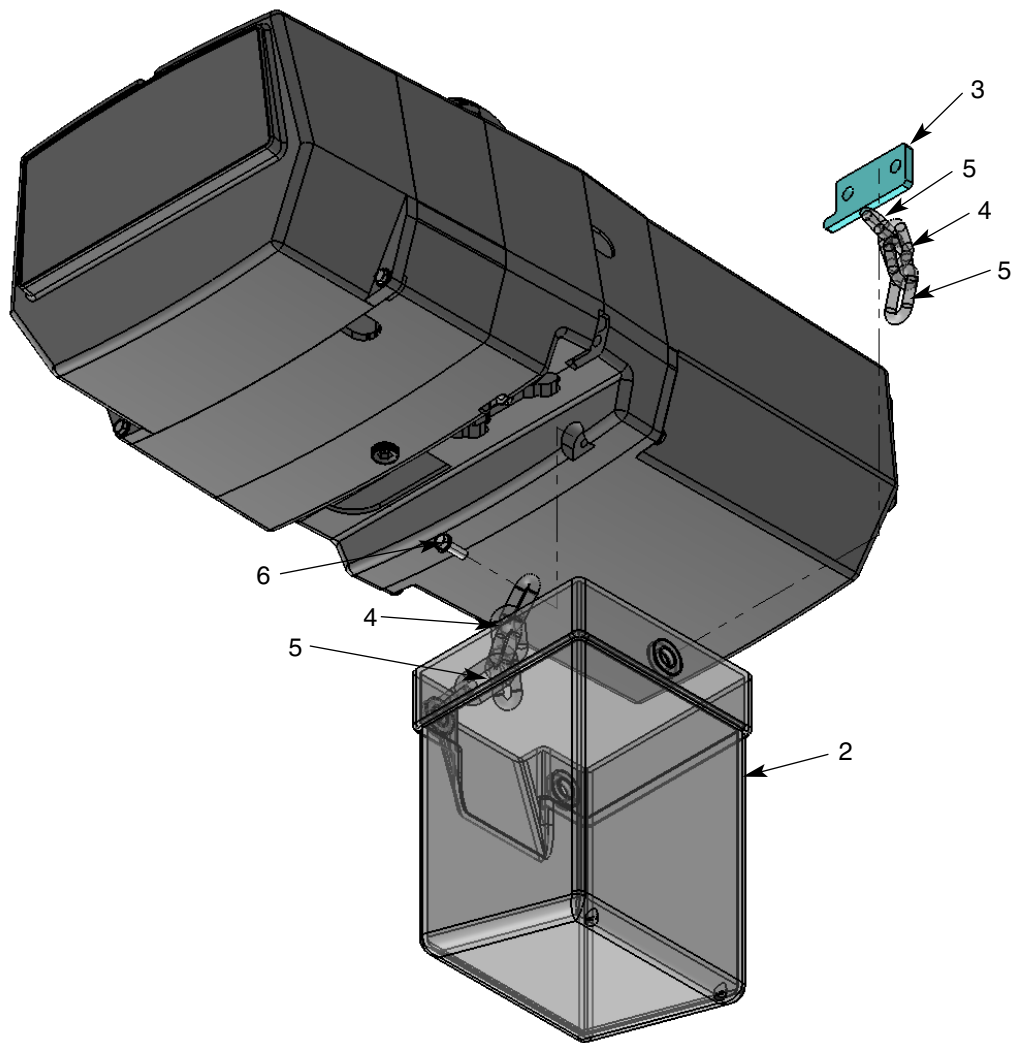

Figure 8-10C. (Double Chain Models)

SECTION IX

DO'S AND DO NOT'S

Electric and Air Powered Hoists

The following warnings and operating practices have been taken from American National (Safety) Standard ANSI B30.16 and are intended to avoid unsafe hoisting practices which might lead to personal injury or property damage. These recommendations apply to all electric and air powered hoists for vertical lifting service involving material handling of freely suspended unguided loads.

WARNING: TO AVOID INJURY

1. DO read ANSI B30.16 Safety Standard for Overhead Hoists and Hoist Manufacturer's Operating and Maintenance Instructions.
2. DO be familiar with hoist operating controls, procedures and warnings.
3. DO make sure hook travel is in the same direction as shown on controls.
4. DO make sure hoist limit switches function properly.
5. DO maintain firm footing when operating hoist.
6. DO make sure that load slings or other approved sling attachments are properly sized and seated in the hook saddle.
7. DO make sure that the hook latch, if used, is closed and not supporting any part of the load.
8. DO make sure that load is free to move and will clear all obstructions.
9. DO take up slack carefully, check load balance, lift a few inches and check load holding action before continuing.
10. DO avoid swinging of load or load hook.
11. DO make sure that all persons stay clear of the suspended load.
12. DO warn personnel of an approaching load.
13. DO protect wire rope and load chain from weld spatter or other damaging contaminants.
14. DO promptly report any malfunction, unusual performance, or damage of the hoist.
15. DO inspect hoist regularly, replace damaged or worn parts, and keep appropriate records of maintenance.
16. DO use the hoist manufacturer's recommended parts when repairing a hoist.
17. DO use hook latches wherever possible.
18. DO apply lubricant to the wire rope or load chain as recommended by the hoist manufacturer.
19. DO NOT lift more than rated load.
20. DO NOT use the hoist load limiting device to measure the load.
21. DO NOT use damaged hoist or hoist that is networking correctly.
22. DO NOT use the hoist with twisted, kinked, damaged or worn wire rope or chain.
23. DO NOT lift a load unless wire rope is properly seated in its groove(s) or unless chain is properly seated in chain wheel (s) or sprocket(s).
24. DO NOT use load rope or load chain as a sling or wrap rope or chain around the load.
25. DO NOT lift a load if any binding prevents equal loading on all supporting ropes or chains.
26. DO NOT apply the load to the tip of the hook.
27. DO NOT operate unless load is centered under hoist.
28. DO NOT allow your attention to be diverted from operating the hoist.
29. DO NOT operate the hoist beyond limits of load rope or load chain travel.
30. DO NOT use limit switches as routine operating stops unless recommended. They are emergency devices only.
31. DO NOT use hoist to lift, support or transport people.
32. DO NOT lift loads over people.
33. DO NOT leave a suspended load unattended unless specific precautions have been taken.
34. DO NOT allow sharp contact between two hoists or between hoist and obstructions.
35. DO NOT allow the rope, chain or hook to be used as a ground for welding.
36. DO NOT allow the rope, chain or hook to be touched by a live welding electrode.
37. DO NOT remove or obscure the warnings on the hoist.
38. DO NOT adjust or repair a hoist unless qualified to perform hoist maintenance.
39. DO NOT attempt to lengthen the load rope or chain or repair damaged load rope or chain.

For replacement parts, call 1-800-477-5003
Please have the following information ready:
-Model number
-Serial number (if any)
-Part description and number as shown in parts list

Notes

For replacement parts, call 1-800-477-5003
Please have the following information ready:
-Model number
-Serial number (if any)
-Part description and number as shown in parts list

Notes

For replacement parts, call 1-800-477-5003
Please have the following information ready:
-Model number
-Serial number (if any)
-Part description and number as shown in parts list

Notes

Country Club Road
P.O. Box 779
Wadesboro, NC 28170 USA
TEL: (800) 477-5003
FAX: (800) 374-6853

COFFING AUTHORIZED WARRANTY REPAIR CENTERS AND PARTS DEPOTS

As a Coffing Hoist user, you are assured of reliable repair and parts services through a network of Master Parts Depots and Service Centers that are strategically located across the United States, its territories and Canada. These facilities have been selected on the basis of their demonstrated ability to handle all parts and repair requirements promptly and efficiently.

Below is a list of the Coffing Authorized Warranty Repair Centers and Parts Depots located in United States, its territories and Canada. To quickly obtain the name of a Service Center located nearest you, call (800) 477-5004. Fax: (800) 374-6853. In the following list, the Canadian Service Centers are indicated.

UNITED STATES

ALABAMA

**TOOL SMITH CO.
1300 4th Ave.S.
Birmingham AL 35233
(205) 323-2576 or (800) 317-8665
Fax (205) 323-9060

ARKANSAS

**HI-SPEED HOIST & CRANE
701 N. Maple St.
N. Little Rock AR 72114
(501) 375-9178 Fax (501) 375-4254

**HANDLING SYSTEMS & CONVEYORS INC
10909 East Otter Creek Rd.
Mabelville AR 72103
(501) 455-5898 Fax (501) 455-6179

ARIZONA

**MECHANICS TOOL SERVICE
1301 E. Apache Park Place
Tucson AZ 85714
(520) 889-8484 AZ only (800) 372-6700
Fax (520) 889-6668

CALIFORNIA

**ARROW CRANE HOIST CORP.
12714 South Carmenita Road
Santa Fe Springs CA 90670
(562) 921-8328 Fax (562) 921-9307

**IDG. CALIFORNIA
6842 Walker Street
LaPalma CA 90623
(714) 994-6960 or (800) 464-5669
Fax (714) 521-0105

**CRANEWORKS, INC.
2585 Nicholson Street
San Leandro CA 94577
(510) 357-4000 Fax (510) 357-4099

COLORADO

**CRANE REPAIR CO.
3718 Norwood Drive
Littleton CO 80125
(303) 791-7918 or (800) 878-7918
Fax (303) 791-7179

FLORIDA

**J. HERBERT CORP.
1751 S. John Young Parkway
Kissimmee FL 32741
(407) 846-0588 or (800) 255-0588
Fax (407) 846-8042

**MATERIAL HANDLING SYSTEMS
720 S.W. 4th Court
Dania FL 33004
(954) 921-1171 or (888) 424-6478
Fax (954) 921-7117

GEORGIA

**ACE INDUSTRIES INC.
6295 McDonough Drive
Norcross GA 30093
(770) 441-0898 or (800) 733-2231
Fax (800) 628-3648

*GAFFEY INC.
471 Sessions St.
Marietta GA 30060
(770) 939-6443 or (800) 820-6443
Fax (770) 422-2255

ILLINOIS

**INDUSTRIAL CRANE
1621 West Chanute Rd.
Peoria IL 61615
(309) 692-0856 or (800) 6425-0856
Fax (309) 692-1034

*S & K AIR POWER
Rt. 316 E., Box 1279
Mattoon IL 61938
(217) 258-8500 (IL only-800-955-8501)
Fax (217) 258-8571

**SIEVERT ELECTRIC SERVICE
1230 South Hannah
Forest Park IL 60130
(708) 771-1600 or (800) 322-9144
Fax (708) 771-3124

INDIANA

**BREHOB CORP.
1334 S. Meridian St.
Indianapolis IN 46225
(317) 231 8080 or (800) 632-4451
Fax (317) 231-8072

**MATERIALS HANDLING EQUIPMENT
7433 US 30 East
Fort Wayne IN 46803
(219) 749-0475 or (800) 443-6432
Fax (219) 749-0481

IOWA

**ALTER & SONS, INC.
514 S. Howell St.
Davenport IA 52808
(563) 323-3601 or (800) 553-1111
Fax (563) 324-0138

KENTUCKY

**ADVANCED SHERMAN
330 North Spring St.
Louisville KY 40206
(502) 896-2166 (KY only-800-633-8186)
Fax (502) 897-9837

LOUISIANA

**PRIME INDUSTRIAL
3301 Cities Service Hwy
West Lake LA 70669
(337) 882-6011
Fax (337) 882-0527

**DRILLCO
12649 S. Choctaw Dr.
Baton Rouge LA 70815
(225) 272-8251 or (800) 851-3821
Fax (800) 315-9225

MASSACHUSETTS

**Abel Distributors, Inc.
50 Parker Street Unit 2
Newburyport, MA. 01950
(978)463-0700
Fax (978) 463-5200

MICHIGAN

*COMMERCIAL GROUP
9955 Grand River
Detroit MI 48204
(313) 931-6100 or (800) 931-7701
Fax (313) 491-1753

**CONTINENTAL CRANE & SERVICE CO.
33681 Groesbeck Hwy.
Fraser MI 48026
(586) 293-3870 Fax (586) 293-0017

**STEWART ENGINEERING & SALES
2140 Aurora Ave.
Muskegon MI 49442
(231) 767-2140 Fax (231) 767-2233

MINNESOTA

**ELECTRIC MOTOR REPAIR, INC.
2010 N. 4th St.
Minneapolis MN 55411
(612) 522-3318 or (800) 345-0198
Fax (612) 588-1617

**J & B EQUIPMENT
8200 Grand Avenue South
Bloomington MN 55420
(952) 884-2040 Fax (952) 346-1139

***PERFECTION CRANE & HOIST INC.
201 DeGraff Ave.
Swanville MN 56382
(320) 547-2401 or (800) 253-6829
Fax (800) 353-2254

**TOTAL TOOL SUPPLY
315 N. Pierce St.
St. Paul MN 55104
(952) 646-4055 or (800) 444-4899
Fax (952) 646-8610

MISSOURI

**HERTZ EQUIPMENT RENTAL & SUPPLY
800 E. 18th St.
Kansas City MO 64108
(816) 221-7788 or (800) 669-7788
Fax (816) 221-0817

**HANDLING SYSTEMS INC.
11678 Gravois Rd.
St. Louis MO 63126
(314) 842-7263 Fax (314) 842-5041

**ZELLER ELECTRIC
4250 Hoffmeister
St. Louis MO 63125
(314) 638-9641 (Outside MO (800) 530-5810)
Fax (314) 638-6318

MONTANA

**POWER SERVICE OF MONTANA, INC.
4025 1st Ave.
Billings Montana 59101
(406) 252-8114 or (800) 823-8665
Fax (406) 259-3956

NEW JERSEY

**SISSCO
186 Route 206 South
Hillsborough NJ 08844
(908) 359-9767 or (800) 392-0146
Fax (908) 359-9773

UNITED STATES

NEW YORK

**ABC ELECTRIC
24-25 46th Street.
Long Island City NY 11103
(718) 956-0000 or (N.Y. only-800-562-1919)
FAX (718) 956-4455

**BEATON INDUSTRIAL, INC.
6083 Trenton Rd.
Utica NY 13502
(315) 797-9346 (N.Y. only-800-724-4052)
Fax (315) 797-9321

**VOLLAND ELECTRIC EQUIPMENT CO.
75 Innsbruck Drive
Buffalo NY 14227
(716) 656-9900 Fax (716) 656-8899

NORTH CAROLINA

**TEAM SESCO
3310 E. Wendover Avenue
Greensboro NC 27405
(336) 375-6050 or (800) 326-3655
Fax (336) 375-6053

**SOUTHERN ELECTRIC SERVICE
2225 Freedom Drive
Charlotte NC 28266
(704) 372-4832 or (800) 487-3726
Fax (704) 342-2604

OHIO

**CRANE AMERICA - H. W. HOUSE
920 Deneen Avenue
Monroe OH 45050
(513) 539-9770 or (800) 331-5326
Fax (513) 539-9577

**AMERICRANE & HOIST CORP.
13224 Enterprise Avenue
Cleveland OH 44135
(216) 267-9100 or (800) 652-1932
Fax (216) 267-9131

OKLAHOMA

**GAFFEY, INC.
9655 E. 522 Road
Claremore OK 74017
(918) 343-1191 or (800) 331-3916
Fax (918) 343-7304

OREGON

**GENERAL TOOL & SUPPLY CO.
2705 N.W. Nicolai
Portland OR 97210
(503) 226-3411 or (800) 783-3411
Fax (503) 778-5518

PENNSYLVANIA

**GLOBE ELECTRIC CO.
200 23rd Street
Pittsburgh PA 15215
(412) 781-2677 or (800) 850-4440
Fax (412) 781-1812

*KEYSTONE CRANE & HOIST CO.
861 S. Washington Road
McMurray PA 15317
(724) 746-5080 Fax (724) 746-5082

**MCDAL CORP.
475 East Church Road
King of Prussia PA 19406
(610) 277-5484 or (800) 626-2325
Fax (610) 277-4690

PENNSYLVANIA (cont'd)

**MORRIS MATERIAL HANDLING
Tinicum Ind. Park Building E
10 Industrial Highway MS 80
Lester PA 19113
(800) 346-2098
Fax (610) 521-5907

**REPAIR UNLIMITED
1730 Rockwell Road
Abington PA 19001
(215) 657-3335 or (800) 369-5891
Fax (215) 784-0343

RHODE ISLAND

**MOTORS, HOIST & CONTROLS INC.
179 Railroad Street
Woonsocket RI 02895
(401) 767-4568 Fax (401) 767-4567

SOUTH CAROLINA

**ENGINEERED SYSTEMS, INC.
1121 Duncan-Reidville Road
Duncan SC 29334
(864) 879-7438 or (800) 879-7438
Fax (864) 848-3143

TENNESSEE

**HOIST & CRANE CO.
2508 Perimeter Place
Nashville TN 37214
(615) 242-3383 or (888) 464-7811
Fax (615) 255-4379

**HI-SPEED ELECTRICAL CO.
3013 Thomas Street
Memphis TN 38127
(901) 357-6231 Fax (901) 357-6238

TEXAS

**ABEL EQUIPMENT CO., INC.
3710 Cavalier Drive
Garland TX 75042
(972) 272-7706 Fax (800) 272-2235

**GAFFEY, INC.
4301 Garland Drive
Ft. Worth TX 76117
(817) 281-1994 or (800) 284-4233
Fax (817) 581-7831

**GAFFEY, INC.
4003 S. County Road 1297
Odessa TX 79765
(915) 563-2897 or (800) 733-0006
Fax (915) 563-4703

**GAFFEY, INC.
1436 N. Duck Creek Road
Cleveland TX 77327
(281) 443-6690 or (800) 233-8179
Fax (281) 592-6984

**HYDRAULIC EQUIPMENT SER.
1021 N. San Jacinto Street
Houston TX 77002
(713) 228-4073 Fax (713) 228-0931

UTAH

**ROCKY MOUNTAIN WIRE ROPE & RIG.
2421 South 2570 West
Salt Lake City UT 84119
(801) 972-4972 or (800) 615-3193
Fax (801) 974-0621

VIRGINIA

**FOLEY MATERIAL HANDLING CO.
11327 Va. Crane Drive
Ashland VA 23005
(804) 798-1343 Fax (804) 798-7843

WASHINGTON

**ING-SEATTLE
5601 1st Avenue S.
Seattle WA 98108
(206) 762-4430 or (800) 767-4430
Fax (206) 762-5329

WISCONSIN

**ALFERI INDUSTRIAL SALES & SERVICE
346 Smith Street
Neenah WI 54956
(920) 722-6483 Fax (920) 722-6489

*LIFT INC.

6667 W. Mill Road
Milwaukee WI 53218
(414) 353-5353 or (800) 728-5438
Fax (414) 353-4444

*TRESTER HOIST & EQUIPMENT
W136 N4863 Campbell Dr. Suite 4
Menomonee Falls WI 53051
(262) 790-0700 or (800) 234-6098
Fax (262) 790-1009

ALBERTA

**KRISTIAN ELECTRIC
4215-64 Avenue SE
Calgary Alberta T2C 2C8
(403) 292-9111

BRITISH COLUMBIA

CANADA

***AIR BRAKE REPAIR
144 W. 5th Avenue
Vancouver British Columbia V5Y 1H7
(604) 879-7754

MANITOBA

***B & B DYNAMO
575 McTavish Street
Winnipeg Manitoba R2J 2W5
(204) 237-6066

ONTARIO

**TORONTO ELECTRIC
72 Crockford Blvd
Scarborough Ontario M1R 3C4
(416) 755-7716

**PRO-CRANE HOIST REPAIRS INC.
2050 Speers Road, Unit 2
Oakville Ontario L6L 2X8
(905) 825-2586

QUEBEC

**LEGER
7995 17th Avenue
Montreal Quebec H1Z 5R2
(514) 376-3050

**UPTOWN LtEE
460 Hubert Street
Laval Quebec H7G 2Y9
(514) 667-1859

*PARTS DEPOT & REPAIR CENTERS

**PARTS DEPOT & WARRANTY REPAIR CENTER

***PARTS DEPOT

COFFING® WARRANTY

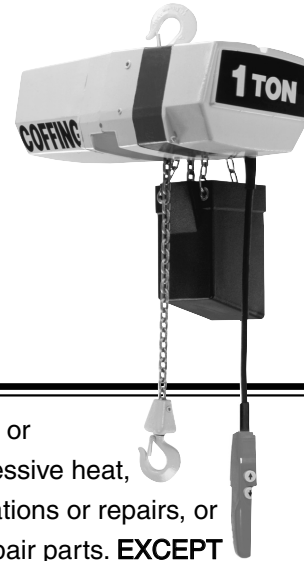

Every hoist is thoroughly inspected and performance tested prior to shipment from the factory. If any properly installed, maintained and operated hoist as outlined in the applicable accompanying Coffing Hoists manual develops a performance problem due to defective materials or workmanship as verified by Coffing Hoists, repair or replacement of the hoist will be made to the original purchaser without charge and the hoist will be returned, transportation prepaid. This warranty does not apply where deterioration is caused by normal wear, abuse, improper or inadequate power supply, improper or inadequate maintenance, eccentric or side loading,

overloading, chemical or abrasive actions, excessive heat, unauthorized modifications or repairs, or use of non-Coffing repair parts. **EXCEPT AS STATED HEREIN, COFFING HOISTS MAKES NO OTHER WARRANTIES, EXPRESS OR IMPLIED, INCLUDING WARRANTIES OF MERCHANTABILITY AND FITNESS FOR A PARTICULAR PURPOSE.**

WARNING

Overloading and Improper Use Can Result In Injury

To Avoid Injury:

- Do not exceed working load limit, load rating, or capacity.
- Do not use to lift people or loads over people.
- Use only alloy chain and attachments for overhead lifting.
- Read and follow all instructions.

COFFING® HOISTS

Coffing Hoists • Country Club Road • P.O. Box 779 •
Wadesboro, North Carolina 28170 USA

Tel: 800.477.5003 • **Fax:** 800.374.6853 • 704.694.6829

www.coffinghoists.com