

**Yale<sup>®</sup> SHAW-BOX<sup>®</sup>**

**YK<sup>™</sup> & SK<sup>™</sup>**

TANDEM ELECTRIC WIRE ROPE HOISTS



COLUMBUS MCKINNON CORPORATION

# Yale® SHAW-BOX®

# YK™ & SK™

## TANDEM ELECTRIC WIRE ROPE HOISTS

CRANE CAPACITIES UP TO 60 TONS (INDIVIDUAL HOIST CAPACITIES OF 30 TONS)

### BENEFITS

#### IMPROVED FACILITY SAFETY

Depending on the material, shape, and size of a load, attempting a lift with a single hoist can potentially cause damage to the product being lifted. Utilizing two hoists in tandem, heavy or long objects can be repositioned horizontally, vertically, or moved simultaneously by both hoists, to prevent load drops and damaged equipment.

#### INCREASED UPTIME

A dual hoist lift is designed to increase efficiency. Using this configuration, the same work can be achieved in half the time as compared to coordinating two hoists separately. Both hoists can be powered and controlled by Magnetek® brand drives and radios, which provide continuous system feedback to enable predictive downtime for maintenance needs.

#### SIMPLE CONFIGURATION

Our improved Compass™ configurator\*, complete with a new user-friendly interface and intuitive navigation, allows you to easily find, configure, and quote a tandem hoist, 24/7. We've improved and simplified the configuration process and provided detailed images of hoists and crane components, so you can see the product as it's configured. Configure your YK and SK tandem hoists in Compass today.

\*Compass is available for our U.S. Channel Partners only.

**Compass**  
BY COLUMBUS MCKINNON

#### FAST DELIVERY

Shipping complete from our Wire Rope Hoist Center of Excellence in Wadesboro, NC, your tandem hoist will include a detailed packing list, assembly manuals, and certification documents, ensuring your crane is up and running quickly.



### MAGNETEK® BRAND RADIOS AND DRIVES

When you order a YK or SK with a variable frequency drive, you'll get the industry-leading safety and performance features you can expect from our Magnetek-brand IMPULSE®-VG+ drives. These drives are designed to help ensure optimal operation of your hoist by continuously monitoring numerous environmental and performance features to keep your operations up and running and your operators working safely.

If you need a radio or pendant control with your YK or SK hoist, our Magnetek-brand products give you the flexibility and performance you need for the job. Our radios offer flexible configurations with over 200 programmable functions to suit all types of applications. Our Magnetek-brand pendants, with standard A/B controls, provide optimal control with less effort and fatigue than traditional pendants.



## OPTIONAL FEATURES

Yale YK and Shaw-Box SK Tandem Hoists are available with the same extensive portfolio of options as our standard wire rope hoist offering. Popular options include:

- Panel and motor heaters
- Patented track wheels
- Travel limit switch
- Towing arm
- Rain covers
- Hoist synchronization
- Sister hooks
- Pendant control
- Plug-and-play socket kit
- Spare parts kit

## OPTIONAL SLD LOAD DISPLAY

Four- and six-digit SLD load displays are available as an option on YK and SK tandem hoists. These displays can be used to show the load of a single hoist or the load summation of up to four hoists. For best load displaying results, test weights in increments of 25%, 50%, 75%, and 100% are required.



## OPTIONAL LOAD SUMMATION

To increase safety by preventing a lift of overloading the crane system, a SMC21E device can be used with up to two hoists for load summation. Available for use with 2-speed/2-speed, 2-speed/VFD, and VFD/VFD configurations, this device can be used to limit the load on each hoist and limit the total combined load of all hoists. One SMC21E is required per hoist and is mounted in the control panel. Hoists cannot be run in the opposite direction at the same time.

Cables, anti-collision devices, and limit switches are not included. Laptop with SMC21E configuration software, shielded CanBus cable to connect the SMC21E device, and a USB cable to connect the SMC21E to a laptop are required for installation.

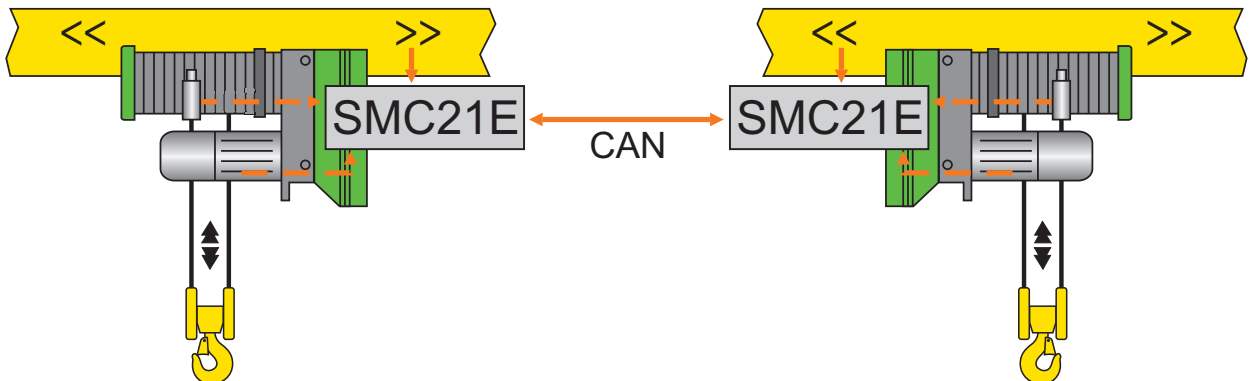



CRANE SOLUTIONS



MAGNETEK

Yale



UNIFIED

[WWW.COLUMBUSMCKINNON.COM](http://WWW.COLUMBUSMCKINNON.COM)

Yale® **SHAW-BOX®**

USA p: 800.888.0985

p: 716.689.5400

f: 716.689.5644

[WIREROPEAPPLICATIONS@CMWORKS.COM](mailto:WIREROPEAPPLICATIONS@CMWORKS.COM)